



## HT-M01S

### LoRa Gateway





## document version

Version	Time	Description
Rev. 1.0	2021-5-19	Preliminary version

## Copyright Notice

All contents in the files are protected by copyright law, and all copyrights are reserved by Chengdu Heltec Automation Technology Co., Ltd. (hereinafter referred to as Heltec). Without written permission, all commercial use of the files from Heltec are forbidden, such as copy, distribute, reproduce the files, etc., but non-commercial purpose, downloaded or printed by individual are welcome.

## Disclaimer

Chengdu Heltec Automation Technology Co., Ltd. reserves the right to change, modify or improve the document and product described herein. Its contents are subject to change without notice. These instructions are intended for you use.



# Content

HT-M01S .....	1
document version .....	2
Copyright Notice .....	2
Disclaimer .....	2
Content .....	3
1. Description .....	4
1.1 Overview .....	4
1.2 Product features .....	5
2. Specifications .....	6
2.1 General specification .....	6
2.2 Operating conditions .....	6
2.3 RF characteristics .....	7
3. Typical hardware connections .....	8
3.1 Physical dimensions .....	8
4. Resource .....	9
4.1 Relevant resource .....	9
4.2 Heltec Contact Information .....	9



# 1. Description

## 1.1 Overview

HT-M01S is positioned as a low-cost standard gateway for indoor use. LoRa part based on the SX1308 + 1255/7 structure, but we innovatively use ESP32 as the main control chip, and use SX1308 ' s hardware driver, data forwarding, and message queue, etc. are completely transplanted to the ESP32 platform without running the Linux operating system. This is the key to its low cost!

It has basic mechanical protection and dustproof structure, but it does not have waterproof performance. It can be connected to the cloud server via Wi-Fi/Ethernet, and the power supply can be Type C 5V or PoE, there also has a 1.8-inch TFT display under the tempered glass panel. Very suitable for deployment in factories, warehouses, homes and other indoor environments that can provide power and network.

HT-M01S are available in three product variants:

Table 1.1 Product model list

No.	Model	Description
1	HT-M01S-470T510	470~510MHz working LoRa frequency, used for China mainland (CN470) LPW band.
2	HT-M01S -863T870	863~870MHz working LoRa frequency, used for EU868, IN865 LPW bands.
3	HT-M01S-902T923	902~923MHz working frequency, used for AS923,





		US915, AU915, KR920 LPW bands.
--	--	--------------------------------

## 1.2 Product features

- CE & FCC Certificate
- Ready to use LoRa Gateway
- System MCU: ESP32
- LoRa baseband: SX1308
- Emulates 49x LoRa demodulators and 1x (G)FSK demodulator
- 10 programmable parallel demodulation paths
- Dynamic data-rate adaptation (ADR)
- Automatic adaptive spread spectrum factor, SF7 to SF12 for each channel is optional
- Maximum output:  $20 \pm 1$  dBm
- Up to -139dBm sensitivity with SX1257 or SX1255 Tx/Rx front-end
- The power supply voltage:5V
- Support for LoRaWAN Class A, Class C protocols
- Through the unique heat conduction device to transfer heat to the aluminum housing, strengthen heat dissipation, make the operation more stable
- -20° C to 70° C maximum operating temperature range
- Working bands: Full band coverage corresponding to the working frequency option.



## 2. Specifications

### 2.1 General specification

Table 2.1 General specification

Parameters	Description
MCU	ESP32-D0WDQ6
LoRa Chipset	SX1301
Interface	Type-C USB x 1; RJ45 x 1; 2.4G Antenna(SMA) x 1;LoRa Antenna(SMA) x 1
Frequency	865~923MHz, 433~510MHz
Max. Receiving sensitivity	-135dBm
Max. TX Power	20 ± 1 dBm <sup>①</sup>
Size	70(+15) x 70 x 23 mm
Operating temperature	-20 ~ 70 °C
Dimensions	70(+11) x 70 x 23 mm

### 2.2 Operating conditions

#### 2.2.1 Power supply range

Table 2.2: Power supply range

Condition	Min.	Typical	Max.	Unit
USB powered (≥500mA)	4.80	5.00	6.00	V
PoE powered (≥500mA)	44	51	57	V

<sup>①</sup> The HT-M01S -470T510 version used in mainland China has a maximum output of 22 ± 2 dBm.



## 2.2.2 Power consumption

Table 2.3: Working current

Condition	Min. <sup>②</sup>	Typical	Max. <sup>③</sup>
8 Channel Listening (Receive mode)		430mA	
LoRa 14dB Output(Typical)		464mA	

## 2.3 RF characteristics

The following table gives typically sensitivity level of the HT-M01S Indoor LoRa gateway.

Table 2.4: LoRa RF characteristics

Signal Bandwidth/[KHz]	Spreading Factor	Sensitivity/[dBm]
125	SF12	-135
125	SF10	-134
125	SF7	-125
125	SF5	-121
250	SF9	-124

② Measured when connected to the Internet via Wi-Fi mode.

③ Measured when connected to the Internet via ethernet mode.



### 3. Typical hardware connections

#### 3.1 Physical dimensions

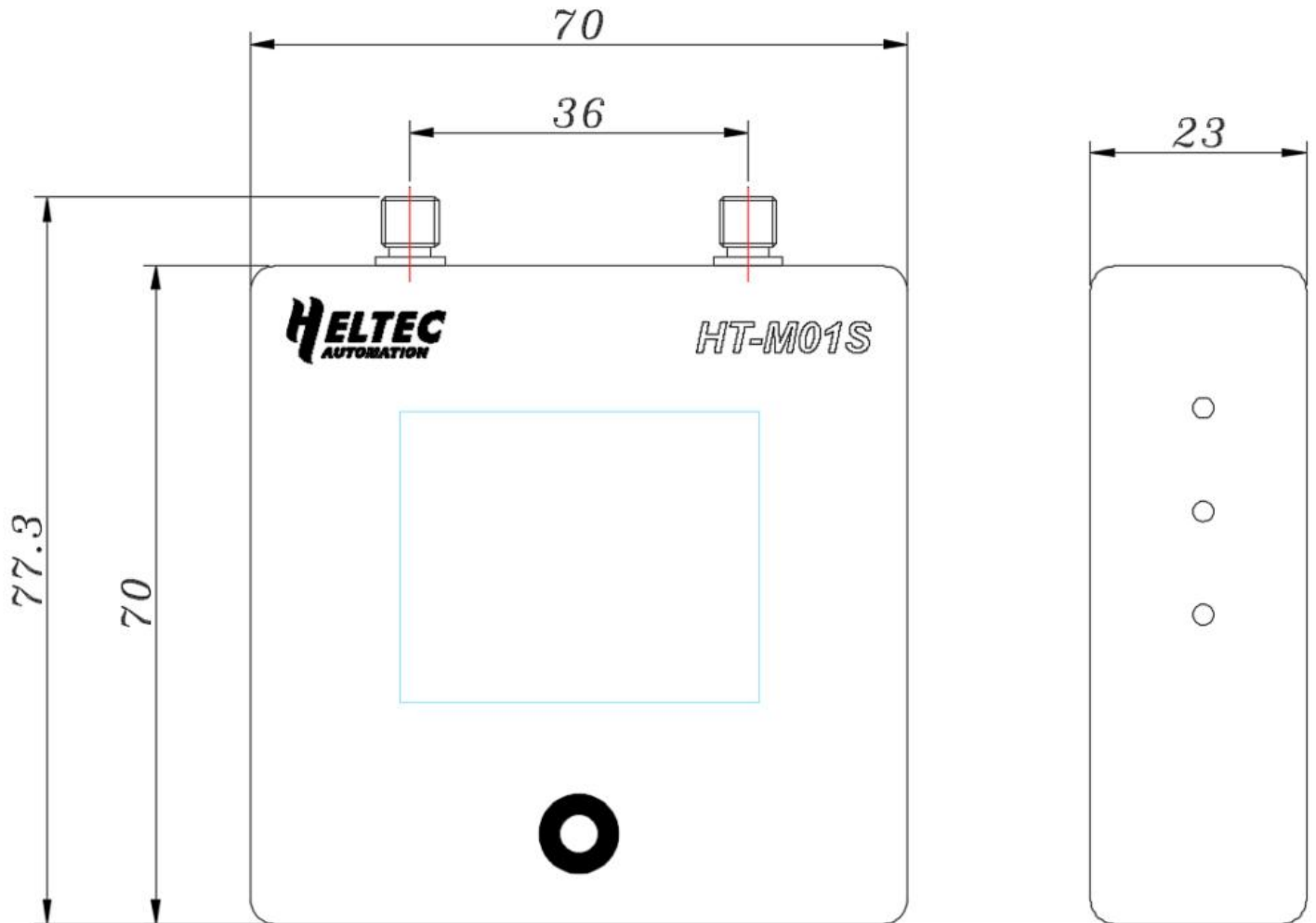





## 4. Resource

### 4.1 Relevant resource

- Downloadable Resources: <https://resource.heltec.cn/download/HT-M01S>

### 4.2 Heltec Contact Information

Heltec Automation Technology Co., Ltd

Chengdu, Sichuan, China

Email: [support@heltec.cn](mailto:support@heltec.cn)

Phone: +86-028-62374838

<https://heltec.org>