

# Wireless Stick Pinout Diagram

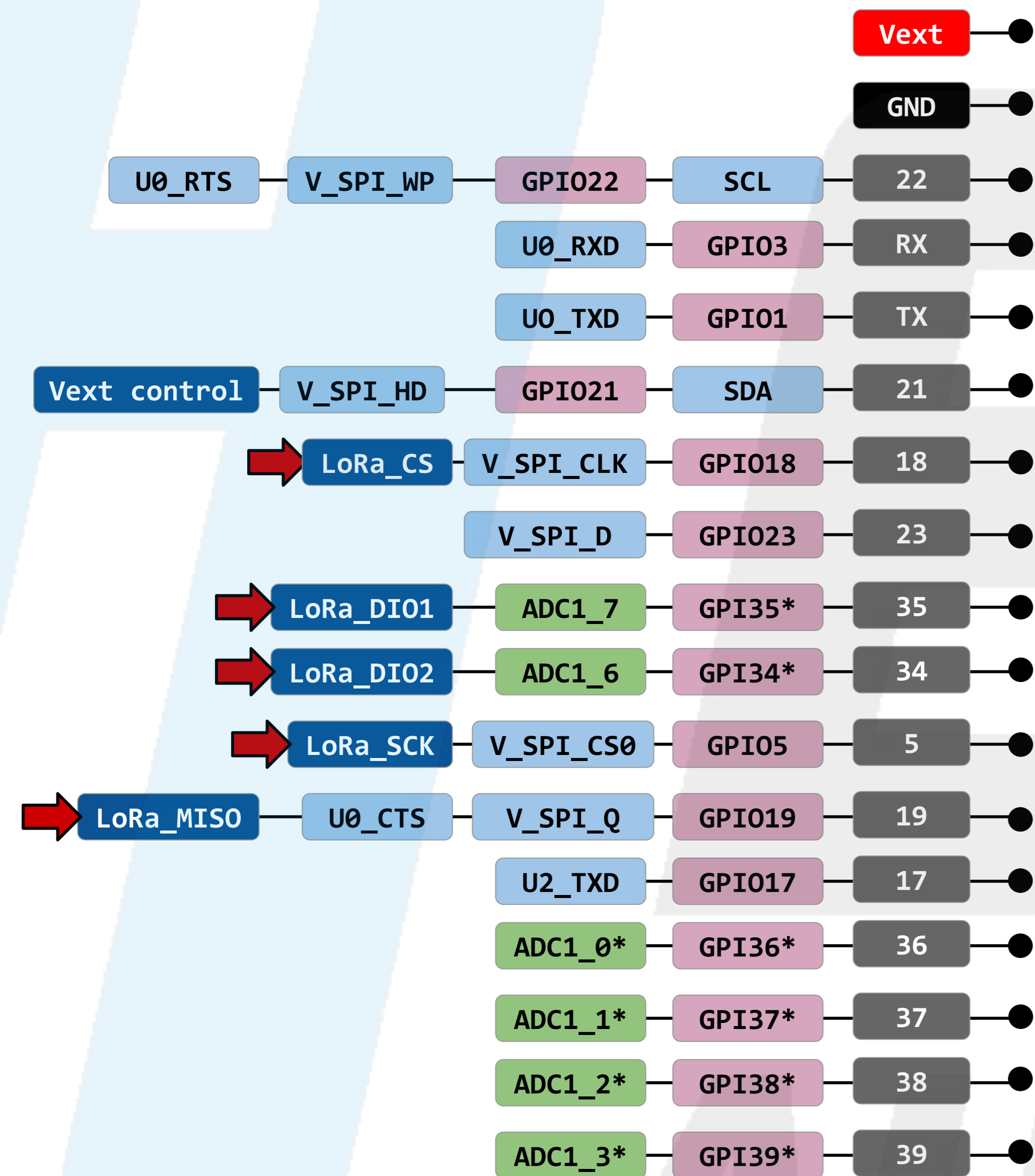

**Notes:**

- Vext : External power supply (3.3V), control the switch of Vext through GPIO(LOW-ON,HIGH-OFF)
- ADC preamplifier GPIOs are 3.3V tolerant only

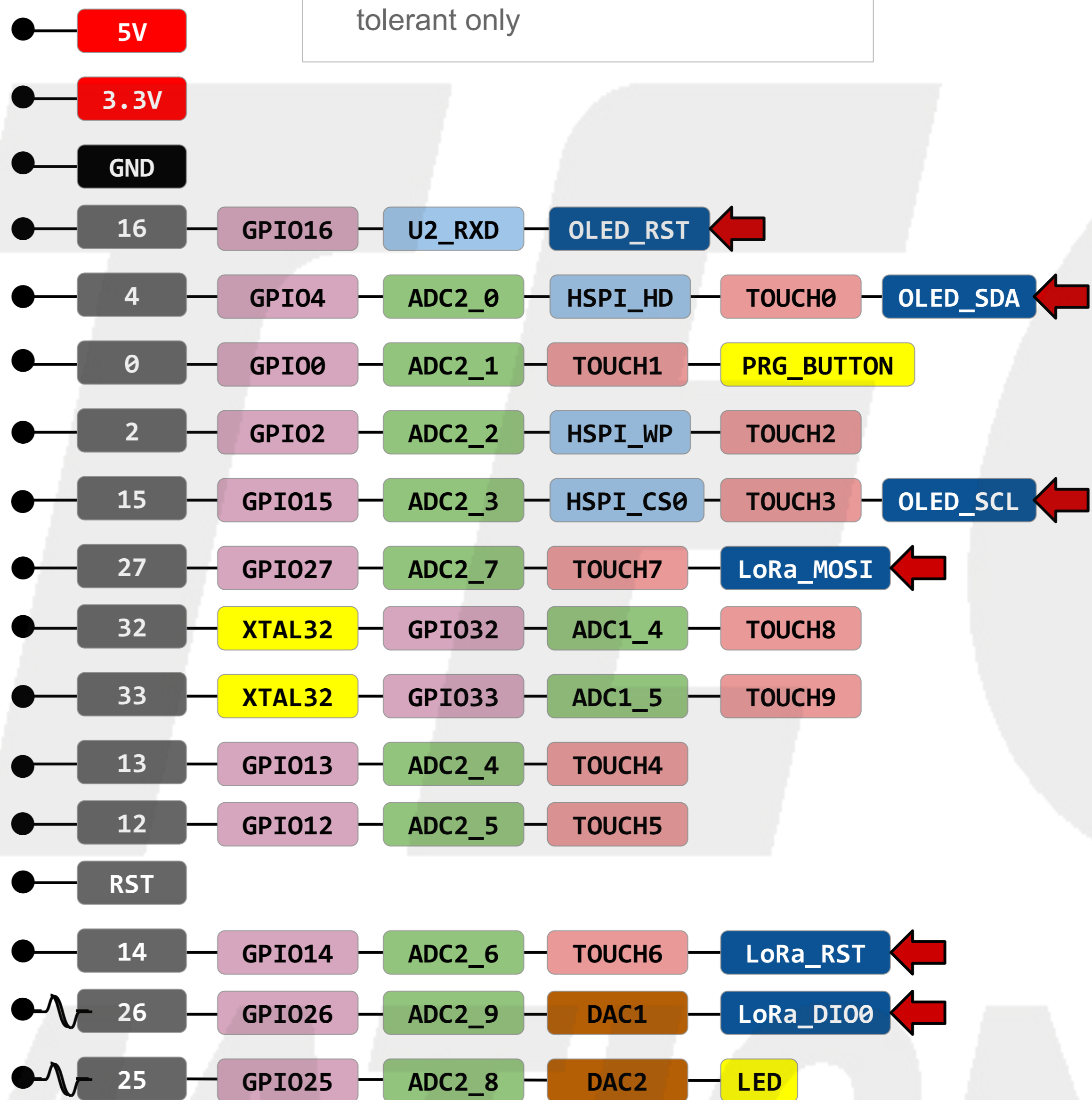

- GND
- Power
- Control
- Touch Pin
- GPIO Port pin
- Analog Pin
- DAC
- Serial SPI I2C
- Physical Pin
- On-board hardware Pin

Pins with this arrow are used by on-board OLED or LoRa, they must not be used for other purpose unless you know what you are doing!