

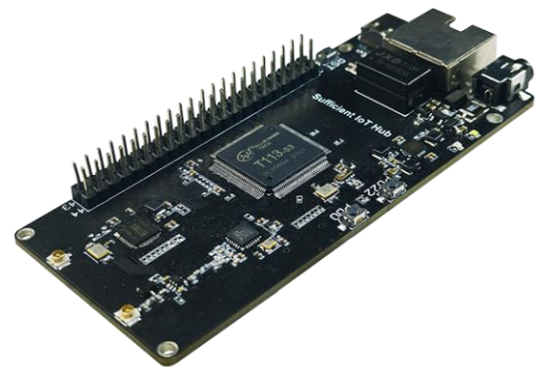

## Sufficient IoT Hub

A Linux Based IoT Terminal Device





## Document version

<i>Version</i>	<i>Time</i>	<i>Description</i>	<i>Remark</i>
<b>V1.0</b>	2022-09-14	Documents creating	



## Copyright Notice

All contents in the files are protected by copyright law, and all copyrights are reserved by Chengdu Heltec Automation Technology Co., Ltd. (hereinafter referred to as Heltec). Without written permission, all commercial use of the files from Heltec are forbidden, such as copy, distribute, reproduce the files, etc., but non-commercial purpose, downloaded or printed by individual are welcome.

## Disclaimer

Chengdu Heltec Automation Technology Co., Ltd. reserves the right to change, modify or improve the document and product described herein. Its contents are subject to change without notice. These instructions are intended for you use.



# Content

<b>Sufficient IoT Hub</b> .....	<b>1</b>
<i>Document version</i> .....	<i>2</i>
<i>Copyright Notice</i> .....	<i>3</i>
<i>Disclaimer</i> .....	<i>3</i>
<i>Content</i> .....	<i>4</i>
<b>1. Sufficient IoT Hub Overview</b> .....	<b>6</b>
1.1 Product Features .....	7
<b>2. Specifications</b> .....	<b>8</b>
2.1 General specifications .....	8
2.2 Operating conditions .....	9
2.2.1 Power supply range .....	9
2.2.2 Power output .....	9
2.2.3 Power characteristics .....	9
2.3 LoRa RF characteristics .....	10
2.3.1 Transmit power .....	10
2.3.2 Receiving sensitivity .....	10
2.4 Board Size .....	11
2.5 Onboard Resource .....	12
2.6 Pin definition .....	13

<https://heltec.org>





- 2.6.1 Pin assignment ..... 13
- 2.6.2 Pin description ..... 13
  
- 3. *Extended Interface* ..... 15
  - 3.1 Power connector ..... 15
  - 3.2 Ethernet Interface ..... 15
  - 3.3 On-board LEDs ..... 16
  - 3.4 Reset button ..... 16
  - 3.5 Debugging Interface ..... 16
  - 3.6 USB Host Port ..... 16
  - 3.7 MicroSD card slot ..... 16
  
- 4. *System* ..... 17
  
- 5. *Supporting modules* ..... 17
  - 5.1 SX1303 LoRaWAN Gateway Module ..... 17
  
- 6. *Resource* ..... 17
  - 6.1 Relevant resource ..... 17
  - 6.2 Heltec Contact Information ..... 17





# 1. Sufficient IoT Hub Overview

The Sufficient IoT Hub is a Linux system-in-package with a dual-core 64-bit ARM A7 processor running at 1GHz and 128MB of DDR3. This is an IoT-only device that includes LoRa, Wi-Fi, and Bluetooth. We created a dedicated **Sufficient IoT OS** for it, which also includes a **CLI application and web UI to operate onboard resources directly**. So that even if the user has no programming experience, they can efficiently operate PWM, I2C, SPI, LoRa, and other protocols to develop whatever they desire. It can, for instance, be used to read sensor data from I2C and transmit it via LoRaWAN, as an MQTT broker, as a LoRa Server in a local area network, or even as a LoRa gateway via an expansion panel.

Sufficient IoT Hub are available in the following product variants:

Table 1.1 Product model list

No.	Model	Description
1	Sufficient IoT Hub (LF)	433~510MHz working LoRa Node frequency, used for China mainland (CN470) LPW band.
2	Sufficient IoT Hub (HF)	For EU868, IN865, US915, AU915, AS923, KR920 and other LPW networks with operating frequencies between 863~928MHz.



## 1.1 Product Features

- Allwinner T1113-S3 processor, Dual-Core ARM Cortex™-A7 800MHz CPU.
  - ✧ 128MB SiP DDR3 RAM, Micro TF card slot.
  - ✧ Work with **Sufficient IoT OS**, a dedicated OS for this device, it's based on Linux (5.4.61 Kernel, 32-bits) Debian 10 Operating system.
  - ✧ Built in **Sufficient IoT application**, allow user to operate onboard resources efficiently.
- On-board Peripherals
  - ✧ XR829 (Wi-Fi and Bluetooth capabilities available)
  - ✧ SX1262 (provides LoRa node functionality)
- On-Board Interface
  - ✧ One 10/100M Ethernet interface (RJ45 connector)
  - ✧ One TF card slot
  - ✧ A three-wire debug serial port
  - ✧ One 5V power input connector
  - ✧ One USB HOST Type C interface
  - ✧ A TWI interface
  - ✧ Two universal UART interfaces
  - ✧ One SPI interface
  - ✧ One ADC interface
  - ✧ Two PWM interfaces
- Interact
  - ✧ A reset button

<https://heltec.org>



- ✧ Two functional button
- ✧ A power light.
- ✧ A user-defined light
- Input power: +5V or +3.3V
- Operating temperature: -40°C~85 °C
- Encryption chip.

## 2. Specifications

### 2.1 General specifications

Table 2-1: General specifications

Parameters	Description
MCU	Dual-Core ARM Cortex™-A7 CPU, 800MHz.
LoRa Chip	SX1262
LoRa Frequency	863~870MHz, 902~928MHz, 470~510MHz
LoRa Max. TX Power	21 ± 1 dBm
Wi-Fi	802.11 b/g/n
Ethernet	100M RJ45 socket
Supply voltage	+5V, +3.3V
Power consumption	Max. ≈ 150mA, standby ≈ 100mA
Operating temperature	-40 ~ 85 °C
Dimensions	90 x 41 x 11 mm
Clock Inputs	<ul style="list-style-type: none"><li>● OSC -- 32.768KHz external crystal.</li><li>● DCXO -- 24MHz external crystal.</li></ul>

<https://heltec.org>





## 2.2 Operating conditions

### 2.2.1 Power supply range

Except when USB or 5V Pin is connected separately, only a single power supply can be connected.

Table 2-2: Power supply range

Power supply mode	Minimum	Typical	Maximum	Company
5V Power Adapter(≥500mA)	4.7	5	5.5	V
Type-C USB(≥500mA)	4.7	5	5.5	V
5V Pin (≥500mA)	4.7	5	5.5	V

### 2.2.2 Power output

Table 2-3: Power output

Output Pin	Minimum	Typical	Maximum	Company
5V Pin			2000	mA
3.3V Pin			2000	mA

### 2.2.3 Power characteristics

Table 2-4: Power characteristics

Mode	Condition	Min.	Typical	Max.	Company
IDLE	USB powered		98		mA
Wi-Fi	USB powered		110		mA
Ethernet	USB powered		100		mA
SX1262_TX	22dBm, USB powered		150		mA

<https://heltec.org>



SX1262_RX	USB powered		108		mA
-----------	-------------	--	-----	--	----

## 2.3 LoRa RF characteristics

### 2.3.1 Transmit power

Table 2-5 Transmit power

Operating frequency band	Maximum power value/[dBm]
470~510 MHz	21 ± 1
867~870 MHz	21 ± 1
902~928 MHz	21 ± 1

### 2.3.2 Receiving sensitivity

The following table gives typically sensitivity level of the Sufficient IoT Hub (L/H).

Table 2-6: Receiving sensitivity.

Signal Bandwidth/[KHz]	Spreading Factor	Sensitivity/[dBm]
125	SF12	-139
125	SF10	-130
125	SF7	-124



## 2.4 Board Size

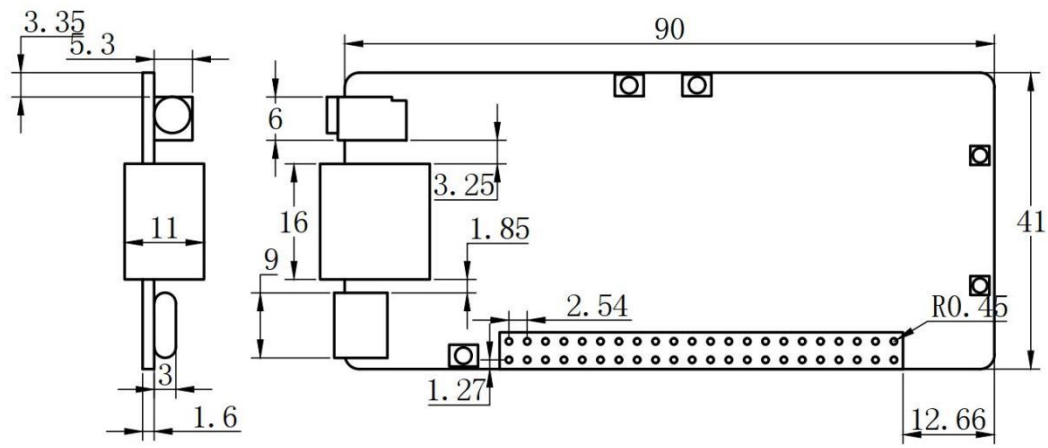

## 2.5 Onboard Resource

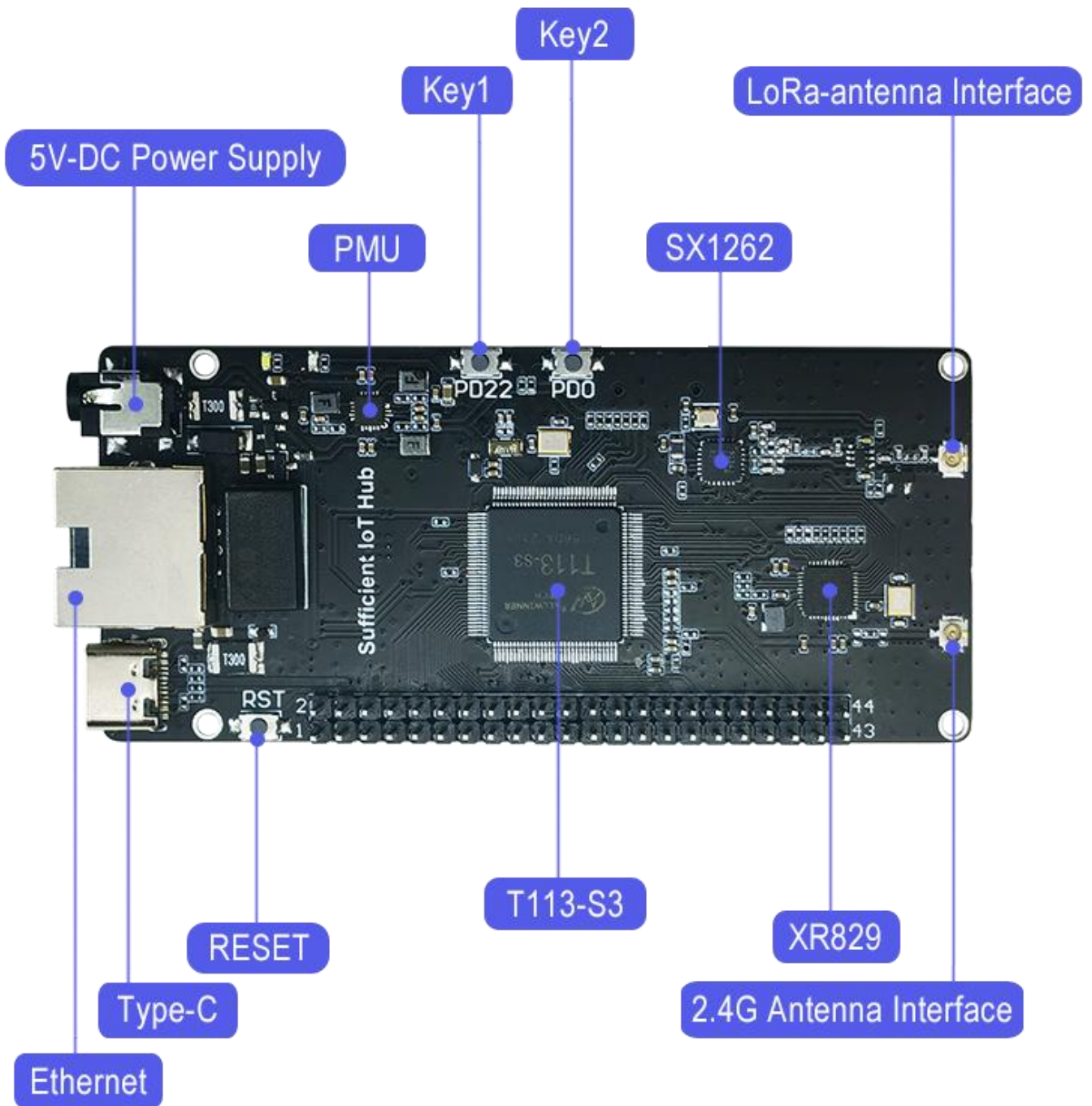



## 2.6 Pin definition

### 2.6.1 Pin assignment

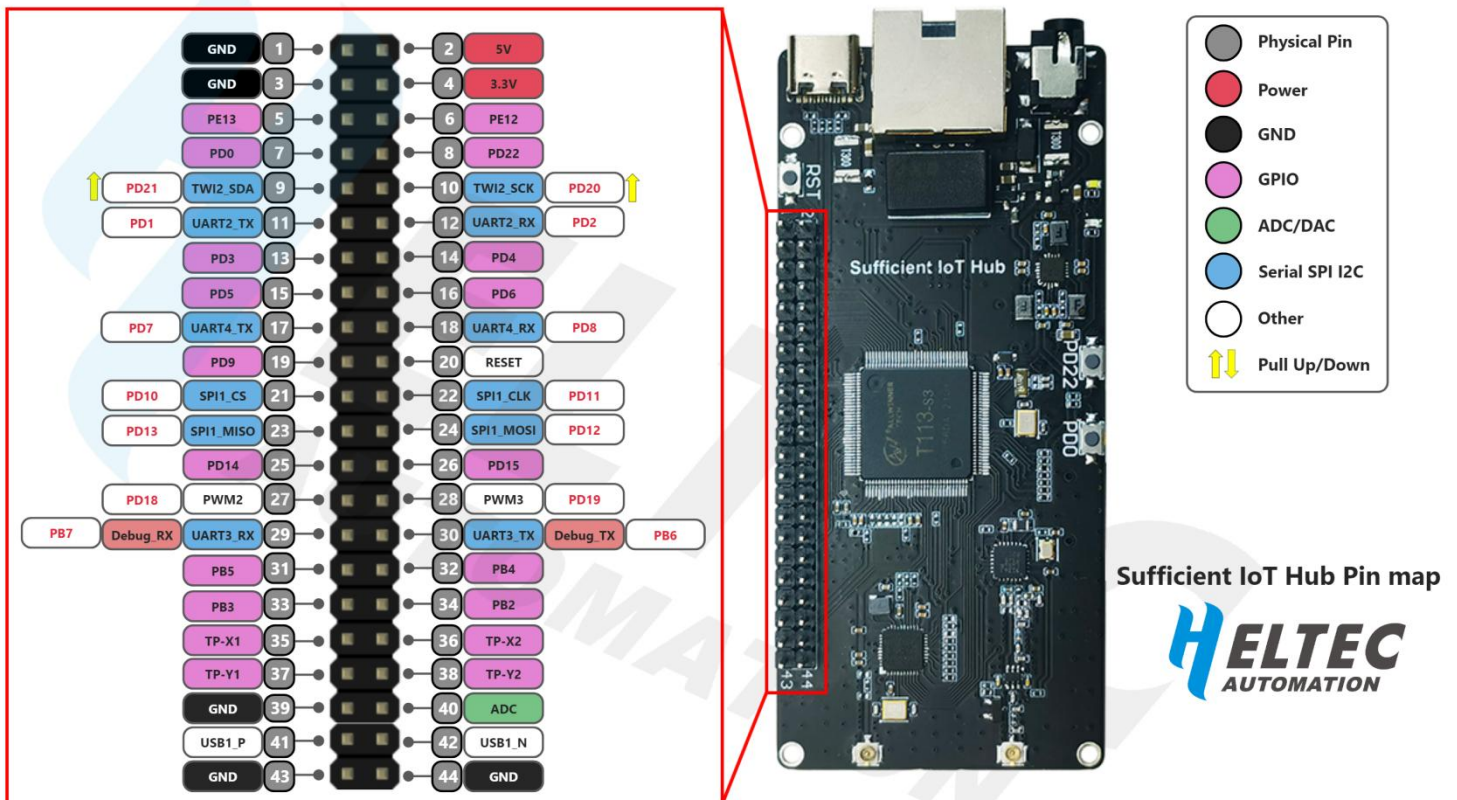

\* The function described in red font is only for illustration, indicating that the pin has been used for special functions and cannot be used as GPIO.

### 2.6.2 Pin description

General purpose GPIO row of 32 pin ports. They allow you to integrate Sufficient IoT Hub into your projects, and these expansion ports can be configured for many different purposes.

<https://heltec.org>





Table 2-7: Sufficient IoT Hub pin description

No.	Name	Type	Function <sup>1</sup>	GPIO NUM (PA0=0) <sup>2</sup>
1	GND	P	Ground.	-
2	5V	P	Input/Output 5V.	-
3	GND	P	Ground	-
4	3.3V	P	Output 3.3V, power supply for external device.	-
5	PE13	I/O	PE13	141
6	PE12	I/O	PE12	140
7	PD0	I/O	PD0, User key.	96
8	PD22	I/O	PD22, User key.	118
9	TWI2_SDA	I/O	PD21 , TWI2_SDA	-
10	TWI2_SCK	I/O	PD20 , TWI2_SCK	-
11	UART2_TX	I/O	PD1 , UART2_TX	-
12	UART2_RX	I/O	PD2 , UART2_RX	-
13	PD3	I/O	PD3	99
14	PD4	I/O	PD4	100
15	PD5	I/O	PD5	101
16	PD6	I/O	PD6	102
17	UART4_TX	I/O	PD7 , UART4_TX	-
18	UART4_RX	I/O	PD8 , UART4_RX	-
19	PD9	I/O	PD9	105
20	RESET	I, OD	Reset Signal (low active)	-
21	SPI1_CS	I/O	PD10 , SPI1_CS	-
22	SPI1_CLK	I/O	PD11 , SPI1_CLK	-
23	SPI1_MISO	I/O	PD13 , SPI1_MISO	-
24	SPI1_MOSI	I/O	PD12 , SPI1_MOSI	-
25	PD14	I/O	PD14	110

<sup>1</sup> The function described in red font is only for illustration, indicating that the pin has been used for special functions and cannot be used as GPIO.

<sup>2</sup> GPIO number in system, the calculation formula is:  $M * 32 + n$  (M is pin group, A=0, B=1, etc.). For example -- PB2:  $1 * 32 + 2 = 34$ .



26	PD15	I/O	PD15	111
27	PD18	I/O	PD18, PWM2	-
28	PD19	I/O	PD19, PWM3	-
29	UART3_RX	I/O	PB7, UART3_RX, debug RX	-
30	UART3_TX	I/O	PB6, UART3_TX, debug TX	-
31	PB5	I/O	PB5	37
32	PB4	I/O	PB4	36
33	PB3	I/O	PB3	35
34	PB2	I/O	PB2	34
35	TP-X1	AI	TP-X1	-
36	TP-X2	AI	TP-X2	-
37	TP-Y1	AI	TP-Y1	-
38	TP-Y2	AI	TP-Y2	-
39	GND	P	Ground	-
40	ADC	AI	ADC	-
41	USB1_P	A I/O	USB1_P	-
42	USB1_N	A I/O	USB1_N	-
43	GND	P	Ground	-
44	GND	P	Ground	-

### 3. Extended Interface

#### 3.1 Power connector

The Sufficient IoT Hub requires an operating voltage of 5V and an operating current of 500mA DC. Most 5V-DC adapters with 2.1mm inner aperture plugs can be used to drive the Sufficient IoT Hub today.

#### 3.2 Ethernet Interface

This is a standard RJ45 Ethernet connector which facilitates your project to access the Internet. You can connect it directly to your router or you can connect it to your



computer to share the Wi-Fi network.

### **3.3 On-board LEDs**

Next to the power connector, there are two LEDs, one is to indicate whether the board is powered or not, and in addition to that, there is another LED which can be programmed by the user.

### **3.4 Reset button**

The reset button is used to reboot the board, and the most logical way to trigger a reboot operation is in the operating system; using a hardware reboot may corrupt the files being processed. Of course, if your system is no longer able to respond to software commands, the reset button is the only way to trigger a reboot.

### **3.5 Debugging Interface**

The development board uses serial port 3 (PB6, PB7) as the debug output serial port, the baud rate of the serial port is 115200, connect the serial port 3 to the computer above the serial software, you can see the printout.

### **3.6 USB Host Port**

The Sufficient IoT Hub is equipped with a USB Host port.

### **3.7 MicroSD card slot**

Instead of a hard drive like a computer, the Sufficient IoT Hub uses a Micro SD as a hard drive to store the operating system, programs and personal data.



## 4. System

Like a computer, the Sufficient IoT Hub has an operating system, which by default uses the open source, free Linux operating system, currently supported by Debian 10.

## 5. Supporting modules

### 5.1 SX1303 LoRaWAN Gateway Module

1. Supports 1303 modules in EU868 band and CN470 band.
2. The ported 1303 source code is included in the system, so plug it in and start using it.

## 6. Resource

### 6.1 Relevant resource

[Contents — sufficient\\_iot\\_hub latest documentation \(heltec.org\)](https://heltec.org)

Datasheet: [Sufficient IoT Hub.pdf \(heltec.cn\)](https://heltec.cn)

### 6.2 Heltec Contact Information

Heltec Automation Technology Co., Ltd

Chengdu, Sichuan, China

Email: [support@heltec.cn](mailto:support@heltec.cn)

Phone: +86-028-62374838

<https://heltec.org>

<https://heltec.org>

Documents

Rev 1.0

P 17 / 17

Feb., 2023

Heltec Automation © Limited standard files