



HT-1303

LoRaWAN Concentrator Module





Document version

Version	Time	Description	Remark
Rev. 1.0	2022-8-16	Preliminary version	肖鸿
Rev. 1.1	2022-10-8	Typographic modification	Aaron
Rev. 1.2	2022-11-7	Modify Block Diagram	肖鸿
Rev.1.3	2024-11-25	Add 1302 chip version	Richard

Copyright Notice

All contents in the files are protected by copyright law, and all copyrights are reserved by Chengdu Heltec Automation Technology Co., Ltd. (hereinafter referred to as Heltec). Without written permission, all commercial use of the files from Heltec are forbidden, such as copy, distribute, reproduce the files, etc., but non-commercial purpose, downloaded or printed by individual are welcome.

Disclaimer

Chengdu Heltec Automation Technology Co., Ltd. reserves the right to change, modify or improve the document and product described herein. Its contents are subject to change without notice. These instructions are intended for you use.



Content

HT-1303	1
Document version	2
Copyright Notice	2
Disclaimer	2
1. Description	4
1.1 Overview	4
1.2 Product features	5
1.3 Function block diagram	6
2. Pin Definition	7
2.1 Pin assignment	7
2.2 Pin description	7
3. Specifications	10
3.1 General specifications	10
3.2 Electrical characteristics	11
3.3 RF characteristics	11
3.4 Operation Frequencies	12
4. Hardware resource	14
4.1 Physical dimensions	14
5. Resource	15
5.1 Relevant Resource	15
5.2 Contact Information	15



1. Description

1.1 Overview

HT-1303 is a LoRa gateway module with industrial standard mini-PCIe express form factor based on SX1303/1302¹ + SX1250 chipset. This mPCIe module can be used in any embedded platform offering a free mPCIe slot with SPI connectivity and capable of providing enough power for the module, enables low-power wide area communication capabilities to your new gateway design or existing industrial routers/computer.

HT-1303 is a complete and cost efficient LoRa gateway solution, offering up to ten programmable parallel demodulation paths, 8 x SF5 ~ SF10 or 8 x SF5 ~ SF12 LoRa demodulators. It can detect uninterrupted combination of packets at 8 different spreading factors and 10 channels with continuous demodulation of up to 16 packets. It targets Internet-of-Things (IoT) applications, covering up to 1000 nodes per square kilometer in an environment with moderate interference.

HT-1303 LoRaWAN concentrator module are available in six product variants:

Table 1.1: Product model list

No.	Model	Frequency band	Transmit power[dBm]
1	HT1303-SPI-470T510	470~510	21±1
2	HT1303-USB-470T510	470~510	21±1
3	HT1303-SPI-863T870	863~870	26±1
4	HT1303-USB-863T870	863~870	26±1
5	HT1303-SPI-902T928	902~928	26±1
6	HT1303-USB-902T928	902~928	26±1

¹ The SX1302 is almost fully compatible with the SX1303



1.2 Product features

- 125kHz LoRa reception with:
 - ✧ 8 x 8 channels LoRa packet detectors.
 - ✧ 8 x SF5-SF12 LoRa demodulators.
 - ✧ 8 x SF5-SF10 LoRa demodulators.
 - ✧ Up to 8 packets can be received simultaneously when Fine Timestamp is enabled.
 - ✧ 125/250/500kHz LoRa demodulator.
 - ✧ (G)FSK demodulator.
- SPI Interface: The SPI interface gives access to the configuration register of SX1303 via a synchronous full-duplex protocol.
- Compact min-PCI express form factor TYP. **50.95*30*10.5mm (W*L*H)**
- Environmentally friendly RoHS compliant
- Voltage of mini PCI-e is 3.3V, compatible with 3G/LTE mPCIe card
- Tx power up to 27dBm, Rx sensitivity down to -139dBm@SF12, BW125kHz

1.3 Function block diagram

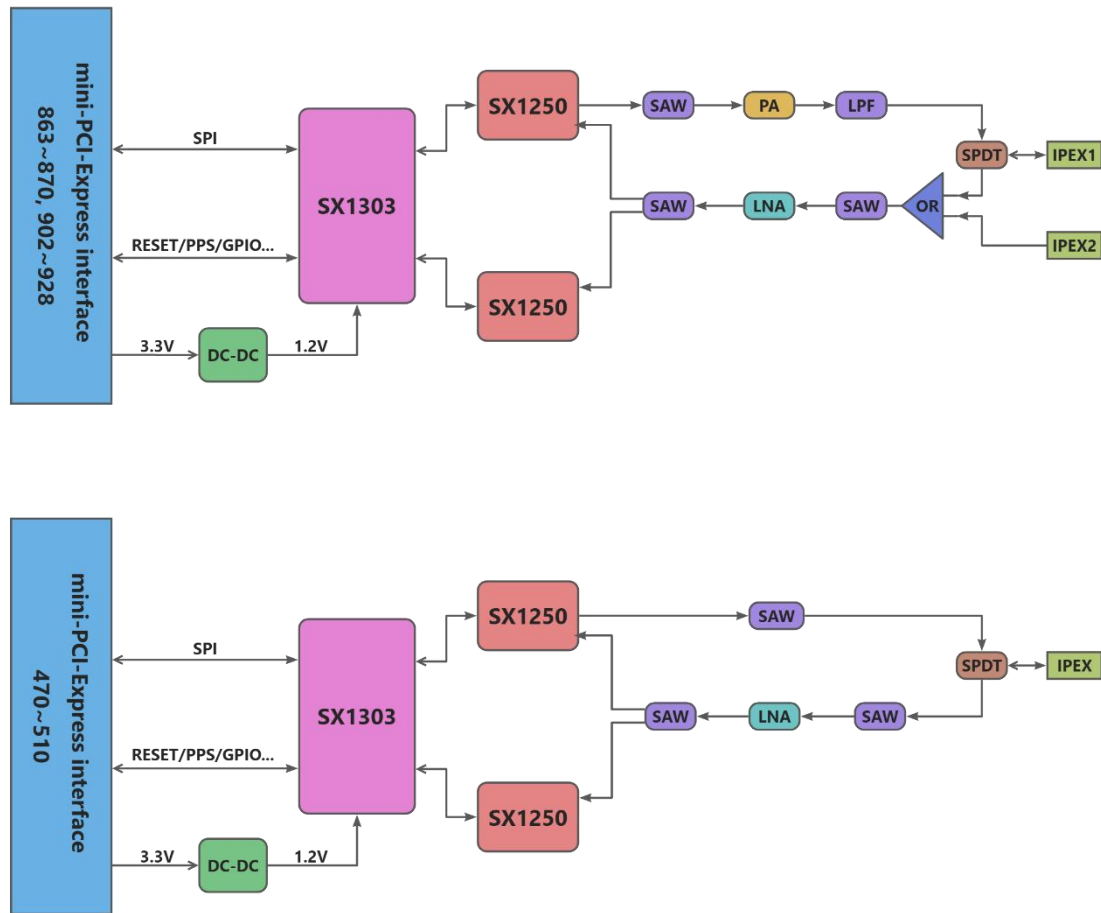

2. Pin Definition

2.1 Pin assignment



HT-1303 Pin map



2.2 Pin description

Table 2.2 Pin definition

No.	Name	Type	Function
1	NC	N/A	No connection
2	3V3	P	3.3V Power supply
3	NC	N/A	No connection
4	GND	P	Ground
5	NC	N/A	No connection



6	NC	N/A	No connection
7	NC	N/A	No connection
8	NC	N/A	No connection. Reserved for SX126x_BUSY .
9	GND	P	Ground
10	NC	N/A	No connection. Reserved for SX126x_NRST .
11	NC	N/A	No connection
12	NC	N/A	No connection
13	NC	N/A	No connection
14	NC	N/A	No connection
15	GND	P	Ground
16	NC	N/A	No connection
17	NC	N/A	No connection
18	GND	P	Ground
19	PPS	O	GPS time pulse input, Leave open if.
20	NC	N/A	No connection
21	GND	P	Ground
22	HOST_RST	I	Active high resets SX1303.
23	NC	N/A	No connection
24	3V3	P	3.3V Power supply
25	NC	N/A	No connection. Reserved for SX126x_CSN .
26	GND	P	Ground
27	GND	P	Ground
28	NC	N/A	No connection



29	GND	P	Ground
30	NC	N/A	No connection. Reserved for internal temperature detection sensor SCL .
31	NC	N/A	No connection. Reserved for SX126x_DIO2 .
32	NC	N/A	No connection. Reserved for internal temperature detection sensor SDA .
33	NC	N/A	No connection. Reserved for SX126x_DIO2 .
34	GND	P	Ground
35	GND	P	Ground
36	NC	N/A	No connection. Reserved for USB_DM .
37	GND	P	Ground
38	NC	N/A	No connection. Reserved for USB_DP .
39	3V3	P	3.3V Power supply
40	GND	P	Ground
41	3V3	P	3.3V Power supply
42	NC	N/A	No connection
43	GND	P	Ground
44	NC	N/A	No connection
45	HOST_SCK	I/O	HOST SPI SCK
46	NC	N/A	No connection
47	HOST_MISO	I/O	HOST SPI MISO
48	NC	N/A	No connection
49	HOST_MOSI	I/O	HOST SPI MOSI



50	GND	P	Ground
51	HOST_CSN	I/O	HOST SPI CSN
52	3V3	P	3.3V Power supply

3. Specifications

3.1 General specifications

Table 3.1: General specification

Parameters	Description
Modulation type	LoRa
LoRa Chipset	SX1303/1302 + SX1250
Frequency	470~510MHz, 863~870MHz, 902~928MHz.
Max. TX Power	470~510MHz: 22dBm; Other: 27dBm.
Max. Receiving sensitivity	-139dBm
Multi-channel	Eight (8) uplink, one (1) downlink.
Host Interface	SPI(Default), USB.
Supply voltage	3.3V@500mA.
Operating temperature	-40~85°C
Dimensions	50.95*30*3mm
Packet	Tape & Reel Packaging



3.2 Electrical characteristics

3.2.1 Power supply

Table 3.2.1: Power supply

Power supply mode	Minimum	Typical	Maximum	Company
3V3 pin($\geq 500\text{mA}$)	2.7	3.3	3.5	V

3.2.2 Power characteristics

Table 3.2.2: Power characteristics

Mode	Condition	Min.	Typical	Max.	Company
TX	868MHz, 3.3V powered, 10dBm		135		mA
	868MHz, 3.3V powered, 14dBm		150		mA
	868MHz, 3.3V powered, 17dBm		200		mA
	868MHz, 3.3V powered, 27dBm		360	420	mA
RX	868MHz, 3.3V powered		40		mA

3.3 RF characteristics

3.3.1 Transmit power

Table 3.3.1: Transmit power

Operating frequency band	Maximum power value/[dBm]
470~510	21 \pm 1
867~870	26 \pm 1



902~928	26±1
---------	------

3.3.2 Receiving sensitivity

The following table gives typically sensitivity level of the HT-1303 concentrator module.

Table 3.3.2: Receiving sensitivity

Signal Bandwidth/[KHz]	Spreading Factor	Sensitivity/[dBm]
125	SF12	-139
125	SF10	-134
125	SF7	-125

3.4 Operation Frequencies

HT-1303 concentrator module supports the following LoRaWAN frequency channels, allowing easy configuration via config files without modify firmware from source code.

Table 3.4: Operation Frequencies

Region	Frequency (MHz)	Model
EU433	433.175~434.665	HT1303-SPI-470T510 HT1303-USB-470T510
CN470	470~510	HT1303-SPI-470T510 HT1303-USB-470T510
IN868	865~867	HT1303-SPI-863T870 HT1303-USB-863T870
EU868	863~870	HT1303-SPI-863T870 HT1303-USB-863T870
US915	902~928	HT1303-SPI-902T928 HT1303-USB-902T928
AU915	915~928	HT1303-SPI-902T928 HT1303-USB-902T928



KR920	920~923	HT1303-SPI-902T928 HT1303-USB-902T928
AS923	920~925	HT1303-SPI-902T928 HT1303-USB-902T928



4. Hardware resource

4.1 Physical dimensions

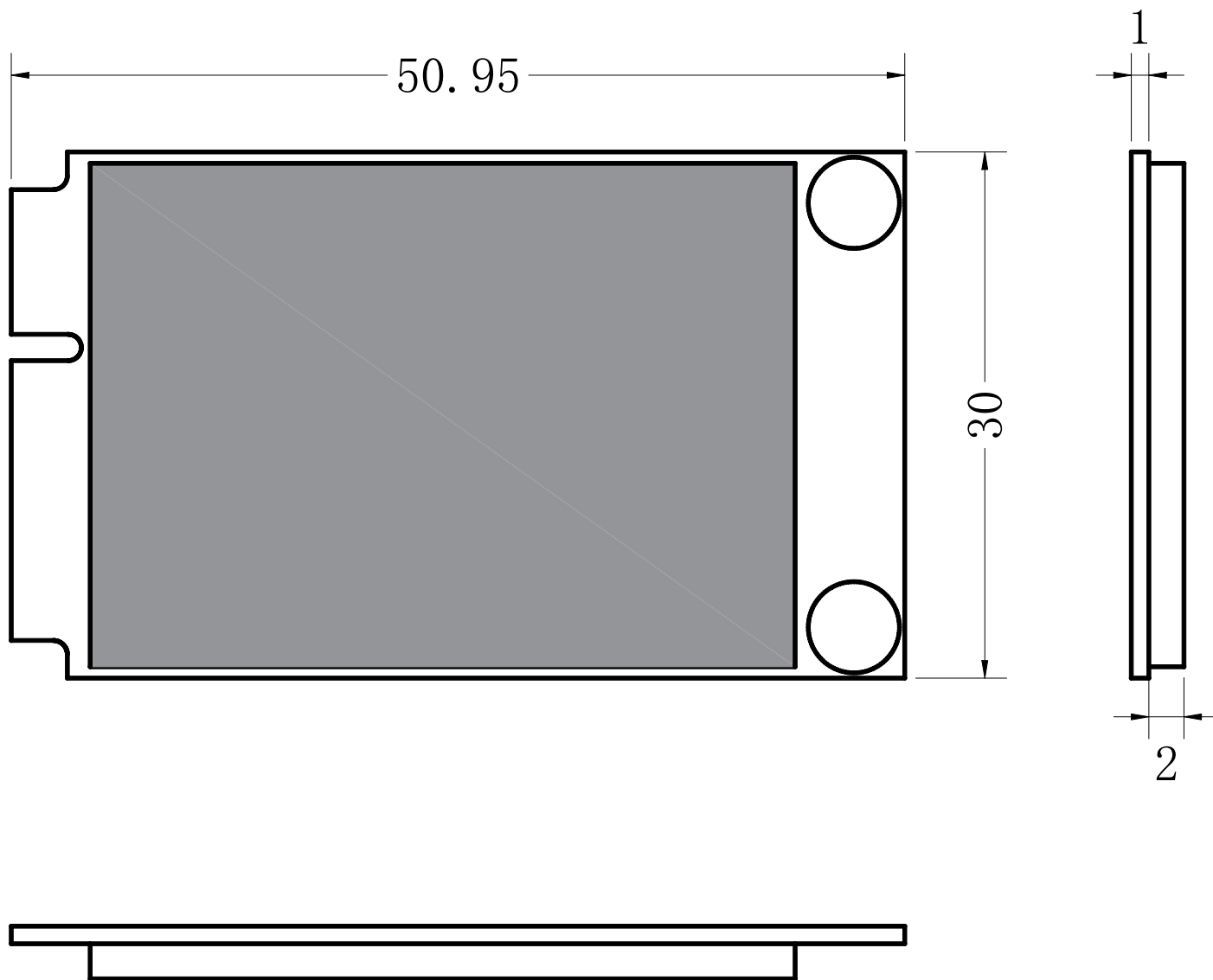



5. Resource

5.1 Relevant Resource

- [Recommend hardware design](#)
- [Pin map](#)
- [Downloadable resource](#)
- [User Guide](#)

5.2 Contact Information

Heltec Automation Technology Co., Ltd

Chengdu, Sichuan, China

Email: support@heltec.cn

Phone: +86-028-62374838

<https://heltec.org>