



MeshPocket

Beyond Charging,

Unleashing a New Wireless Connectivity Experience



Document version

Version	Time	Description	Remark
Rev. 1.0	2024-9-16	Preliminary version	Richard

Copyright Notice

All contents in the files are protected by copyright law, and all copyrights are reserved by Chengdu Heltec Automation Technology Co., Ltd. (hereinafter referred to as Heltec). Without written permission, all commercial use of the files from Heltec are forbidden, such as copy, distribute, reproduce the files, etc., but non-commercial purpose, downloaded or printed by individual are welcome.

Disclaimer

Chengdu Heltec Automation Technology Co., Ltd. reserves the right to change, modify or improve the document and product described herein. Its contents are subject to change without notice. These instructions are intended for you use.

Content

MeshPocket	1
Document version	2
Copyright Notice	2
Disclaimer	2
1. Overview	4
1.1 Introduction	4
1.2 Features	5
2. Specifications	6
2.1 Generic Parameter	6
2.2 Power Consumption	7
2.3 LoRa RF Characteristics	7
2.4 RGB Description	8
2.5 Button Description	9
3. Get Started	10
3.1 Wireless charging	10
3.2 Wired charging	10
3.3 Charging the power bank	11
4. Hardware	12
4.1 Dimensions	12
4.2 Components	12
5. Precautions	13
6. Resource	15
7. Heltec Contact Information	15

1. Overview

1.1 Introduction

Tired of traditional power banks with limited functionality? MeshPocket will exceed your expectations! It's not just a powerful wireless power bank — it's an intelligent device equipped with Bluetooth, LoRa long-range communication, and an e-ink display, making it a perfect companion for open-source projects like Meshtastic and opening new possibilities for wireless connectivity.

MeshPocket is powered by a 5000mAh high-capacity battery, ensuring long time usage. It supports the Qi2 wireless charging protocol, making it compatible with mainstream wireless charging devices. Offering 5W, 7.5W, 10W, and 15W wireless charging options, it meets the diverse power needs of various devices.

The USB-C port supports 9V-2.22A / 5V-3A input or output, allows simultaneous charging and discharging, and enables both wireless and wired discharging at the same time.

Equipped with the nRF52840 chip and high-performance SX1262 LoRa RF chip, offers a transmission range of up to 10 kilometers. The 2.13-inch e-ink display ensures clear visibility even under sunlight, with minimal power consumption.

With these features, MeshPocket is the ideal solution for Meshtastic users, combining reliable power delivery with outstanding connectivity, making it is not just a power bank, but perfect for outdoor adventures and emergency communication.

1.2 Features

- **Powerful Charging Capabilities**

- 5000mAh/10000mAh battery.
- Wireless Charging Support 5W, 7.5W, 10W, and 15W.
- Qi2 compatibility.
- Features robust USB-C ports with input and output capabilities of 9V-2.22A and 5V-3A, providing rapid charging both ways.
- Protocol Compatibility: Supports industry-standard protocols like PD, AFC, and Huawei adapter protocols.
- Supports input overvoltage and undervoltage protection, output overcurrent and short circuit protection, battery undervoltage protection, NTC temperature protection, chip temperature protection, and charging timeout protection.

- **Advanced Wireless Communication**

- Integrates the nRF52840 chip for BLE.
- Features the SX1262 LoRa module, offering long-range communication capabilities with a 10 km transmission range.

- **Innovative Display & Customization**

- Equipped with a 2.13-inch e-ink display, providing clear, power-efficient information updates even in direct sunlight.
- Offers full custom firmware support, allowing developers to adapt it for specialized applications.

- **Perfect for Meshtastic Users**

Seamlessly compatible with **Meshtastic**, MeshPocket is an excellent choice for those seeking a powerful yet compact solution for long-range wireless communication.

2. Specifications

2.1 Generic Parameter

Table 2.1 General specification

Parameters	Description
Battery capacity	5000mAh/3.87V(19.35Wh) 10000mAh/3.87V(38.7Wh)
Rated capacity	3500mAh(5V-2A) 7000mAh(5V-2A)
Battery type	Lithium polymer battery
Battery charging limit voltage	4.4V
Charging time	2.5 hours
Charging temperature	0°C~45°C
Discharging temperature	-10°C~45°C
Storage temperature	-20°C~55°C
Type-C input	9V-2.22A, 5V-3A
Type-C output	9V-2.22A, 5V-3A
Wireless Charging output	5W, 7.5W, 10W, 15W
Waterproof Rating	None
Charge+Discharge	USB-C output (10W) + Wireless charging (5W)
Shell material	ABS, Tempered glass
Weight	140g
Dimensions	102.00*74.10*10.80 (unit: mm)
RF chip	nRF52840(BLE), SX1262(LoRa)
E-Ink	2.13 Inch,

2.2 Power Consumption

Table2.2 Power consumption

Mode	Condition	470MHz	868MHz	915MHz
LoRa_TX	5dBm		83mA	93mA
	10dBm		108mA	122mA
	15dBm		136mA	151mA
	20dBm		157mA	164mA
BT	UART		93mA	
	Scan		132mA	
Sleep			11uA	

2.3 LoRa RF Characteristics

2.3.1 Receiver Sensitivities (dBm)

Table2.3.1 Receiver sensitivities

Signal Bandwidth/[KHz]	Spreading Factor	Sensitivity/[dBm]
125	SF12	-135
125	SF10	-130
125	SF7	-124

2.3.2 Transmitter Power (dBm)

Table2.3.2 Transmitter power

Operating frequency band	Maximum power value/[dBm]
470~510	21 ± 1
863~870	21 ± 1
902~928	21 ± 1

2.4 RGB Description

Table2.4 RGB Status Indicator Description

Status		Indicator
Remaining battery	71%-100%	Green light on steadily
	31%-70%	Yellow light on steadily
	11%-30%	Red light on steadily
	5%-10%	Red light flashing slowly at 0.5Hz.
Over-discharge/no power	≤5%	The red light flashes rapidly at 2Hz. Extinguishes after 5 seconds ^①
	1-30%	Red light flashing slowly at 0.5Hz.
	31-70%	Yellow light flashing slowly at 0.5Hz.
	71-100%	Green light flashing slowly at 0.5Hz.
Fully charged		Green light on steadily
Standby (button triggered) ^②		The current battery level color flashes at 1Hz and extinguishes after 5 seconds.
Foreign Object Detection (FOD)		Yellow light flashes rapidly at 2Hz. After 5 seconds extinguishes.
Fault		Indicator light extinguishes, output shuts down

^① It extinguishes and the wired/wireless charging output is turned off, but power can still be supplied to the wireless communication section.

^② After touch sensing, if the wireless charger is not connected to a load, the light will not illuminate.

2.5 Button Description

Table2.5 Button description

Button	Status	Description
Power	Single click	Turns on output, and the power indicator shows the current battery level.
	Double click	Turns off output, the indicator light turns off, and the wireless charging function enters sleep mode, but the 3.3V DCDC output remains active.
	Long press	Long press the button for 2 seconds: Enables or disables low current mode.
USER	Single click	Meshtastic display switching, Wake up
	Long press	Meshtastic sleep
RST	Single click	Reset Meshtastic

3. Get Started

3.1 Wireless charging

This product supports the automatic induction charging function of magnetic mobile phones. You only need to place the magnetic mobile phone on the magnetic wireless charging area of the mobile power supply to charge normally.

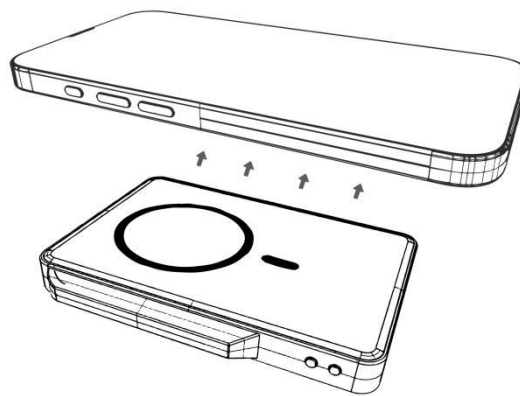

3.2 Wired charging

Use the Type-C data cable to connect the device to be charged and the magnetic power bank to charge the device to be charged.

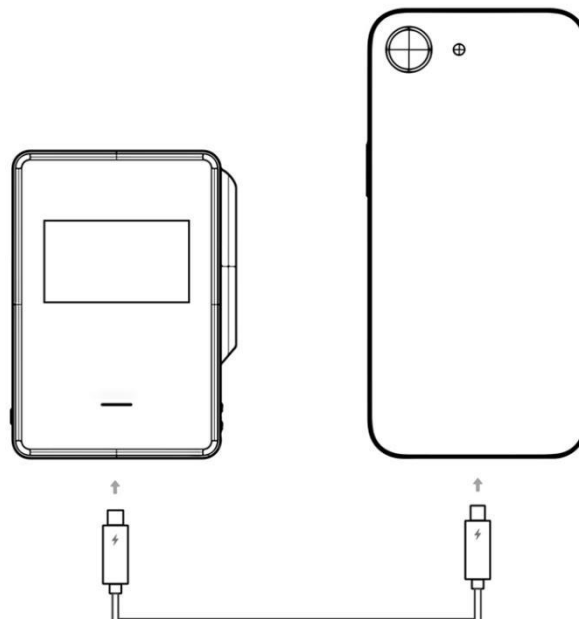

3.3 Charging the power bank

Connect one end of the Type-C data cable to the Type-C interface of the mobile power supply, and then connect the other end to the charger to charge the mobile power supply. During charging, the corresponding power indicator light flashes and the remaining power is displayed.

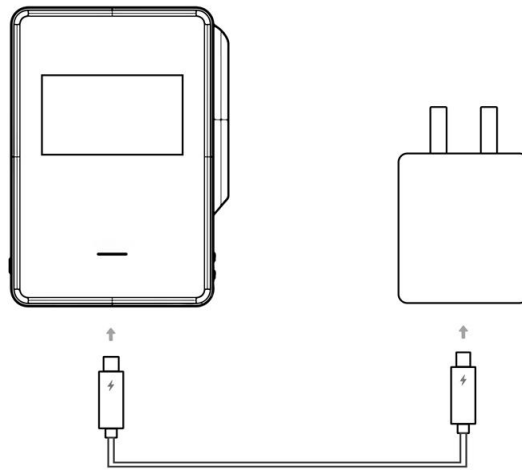

Note: Please note that Meshtastic will continuously consume power. When you do not need to use Meshtastic, press and hold the USER button on the side to turn off this function. To enable this function, simply press the RST button.

4. Hardware

4.1 Dimensions

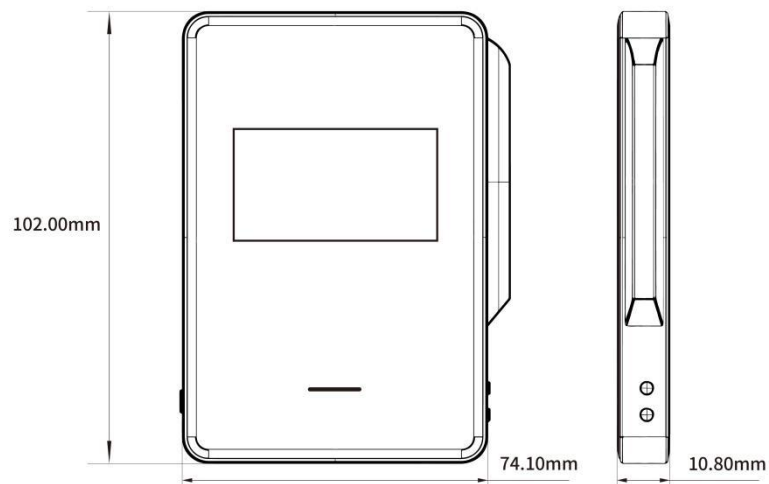

4.2 Components

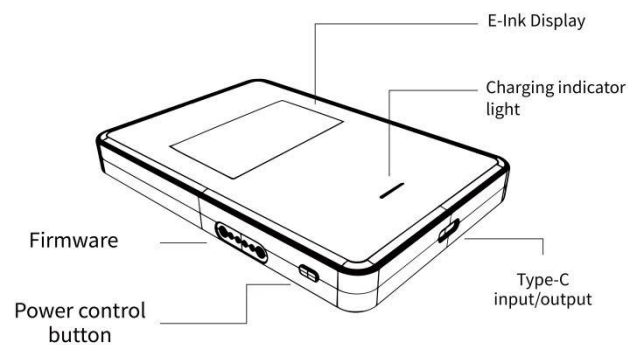

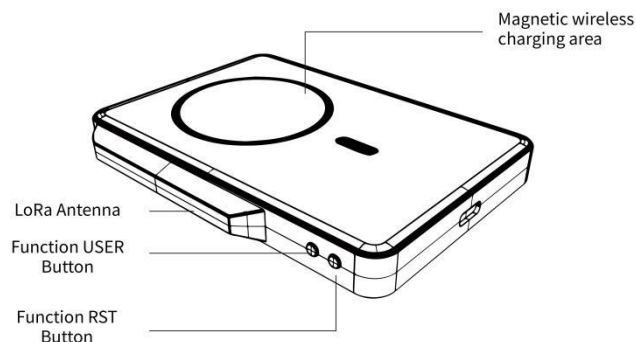

5. Precautions

1. When the wireless charging output is abnormal or a foreign object (FOD) is detected, the wireless charging indicator light flashes yellow and recovers within 5S after it is released.
2. You can manipulate the Meshtastic interface with the buttons on the right side.
3. To ensure battery life, please charge it at least once every three months.
4. Do not expose this product to high-temperature environments or around heating equipment, such as cars, sunlight, heaters, microwave ovens, ovens and other high-temperature environments, as it may cause an explosion.
5. It is strictly prohibited to use unapproved or incompatible power adapters, charging cables, etc., which may cause fire, explosion or other dangers. Please use original or certified data cables.
6. Do not leave this product in an unventilated space for a long time, such as a handbag, etc. Confined spaces can easily cause fire and other dangers.

7. This product contains lithium-ion batteries. It is strictly prohibited to disassemble the product casing without permission to avoid damage to the battery core or fire hazard.

8. Do not drop, squeeze, puncture, short-circuit this product, or put it into water or fire to avoid fire hazards. Please dispose of this product in accordance with local regulations. Do not dispose of this product as domestic waste. Improper disposal may cause explode.

9. Please do not use this product during thunderstorms to avoid product failure or click hazards.

10. Do not come into contact with liquids and avoid dropping the product. If the product has battery swelling, leakage, deformation, etc., please stop using it.

11. Please keep this product out of reach of children.

6. Resource

- User guide: [Heltec Products Operation Documention](#)
- Resource station: resource.heltec.cn

7. Heltec Contact Information

Heltec Automation Technology Co., Ltd

Chengdu, Sichuan, China

Email: support@heltec.cn

Phone: +86-028-62374838

<https://heltec.org>