



Mesh Node T096

Bluetooth, LoRa & GNSS, 0.96 TFT



Document Version

Version	Time	Description	Remark
Rev. 1.0.0	2026-3-25		Richard

Copyright Notice

All contents in the files are protected by copyright law, and all copyrights are reserved by Chengdu Heltec Automation Technology Co., Ltd. (hereinafter referred to as Heltec). Without written permission, all commercial use of the files from Heltec are forbidden, such as copy, distribute, reproduce the files, etc., but non-commercial purpose, downloaded or printed by individual are welcome.

Disclaimer

Chengdu Heltec Automation Technology Co., Ltd. reserves the right to change, modify or improve the document and product described herein. Its contents are subject to change without notice. These instructions are intended for you use.

Content

Mesh Node T096	1
1 Description	4
1.1 Overview	4
1.2 Product Features	4
1.3 Typical Application Scenarios	4
2 Pin Definition	5
2.1 P2	6
2.2 P3	7
2.3 Unrouted pins	8
3 Specifications	9
3.1 General Specification	9
3.2 Power Consumption	9
3.3 Transmit Power	10
3.4 Operation Frequencies	10
4 Physical Dimensions	11
5 Resource	11
6 Heltec Contact Information	12

1 Description

1.1 Overview

Mesh Node T096 is a low-power development board that integrates Bluetooth, LoRa, and GNSS. At its core, the nRF52840 MCU provides ample processing power and Bluetooth connectivity, while the SX1262 LoRa transceiver—integrated with PA—delivers transmit power of 28 ± 1 dBm, ensuring exceptional range and link reliability. The UC6580 GNSS chip enables precise global positioning, making the device ideal for decentralized mesh networks, asset tracking, and remote sensing.

Utilizing Laser Direct Structuring (LDS) technology for both GNSS and Bluetooth antennas, the T096 achieves a compact, durable, and highly efficient antenna solution. Engineered for low-power operation, it is perfectly suited for battery-powered deployments. Fully supported by the Arduino development environment and compatible with open-source mesh projects such as Meshtastic and MeshCore, the Mesh Node T096 offers developers and enthusiasts a versatile, ready-to-use platform for building resilient, scalable mesh networks.

1.2 Product Features

- Based on nRF52840 (Bluetooth), SX1262(LoRa), and UC6580(GNSS).
- Low power consumption, 13 μ A in deep sleep.
- Onboard 0.96 inch TFT-LCD display contains 80(H)RGB x 160(V) dots.
- Type-C USB interface with a complete voltage regulator, ESD protection, short circuit protection, RF shielding, and other protection measures.
- CN3165 lithium battery charge management IC features built-in adaptive current regulation for efficient and safe charging.
- Various Interfaces: 2*1.25 LiPo connector, 2*1.25 Solar panel connector.
- Compatible with Arduino, and we provide [Arduino development frameworks and libraries](#).

1.3 Typical Application Scenarios

- Decentralized Outdoor Mesh Communication
- Asset Tracking and Position Monitoring
- Emergency and Disaster Communication Networks
- Environmental Monitoring and Remote Sensing
- Open-Source Mesh Experimentation and Education
- Portable Personal Communication Device

<https://heltec.org>

2 Pin Definition

About **SPI, I2C, UART, PWM, QPSI, I2S, PDM, QDEC**: Each IO pin is preconfigured with IO_MUX functionality, which means you can use any GPIO as peripheral pins. You just need to define these pins in your code.

However, it's important to note that once a pin is used, it may affect other functions associated with that pin. For information, please refer to the [Schemaic diagram](#).

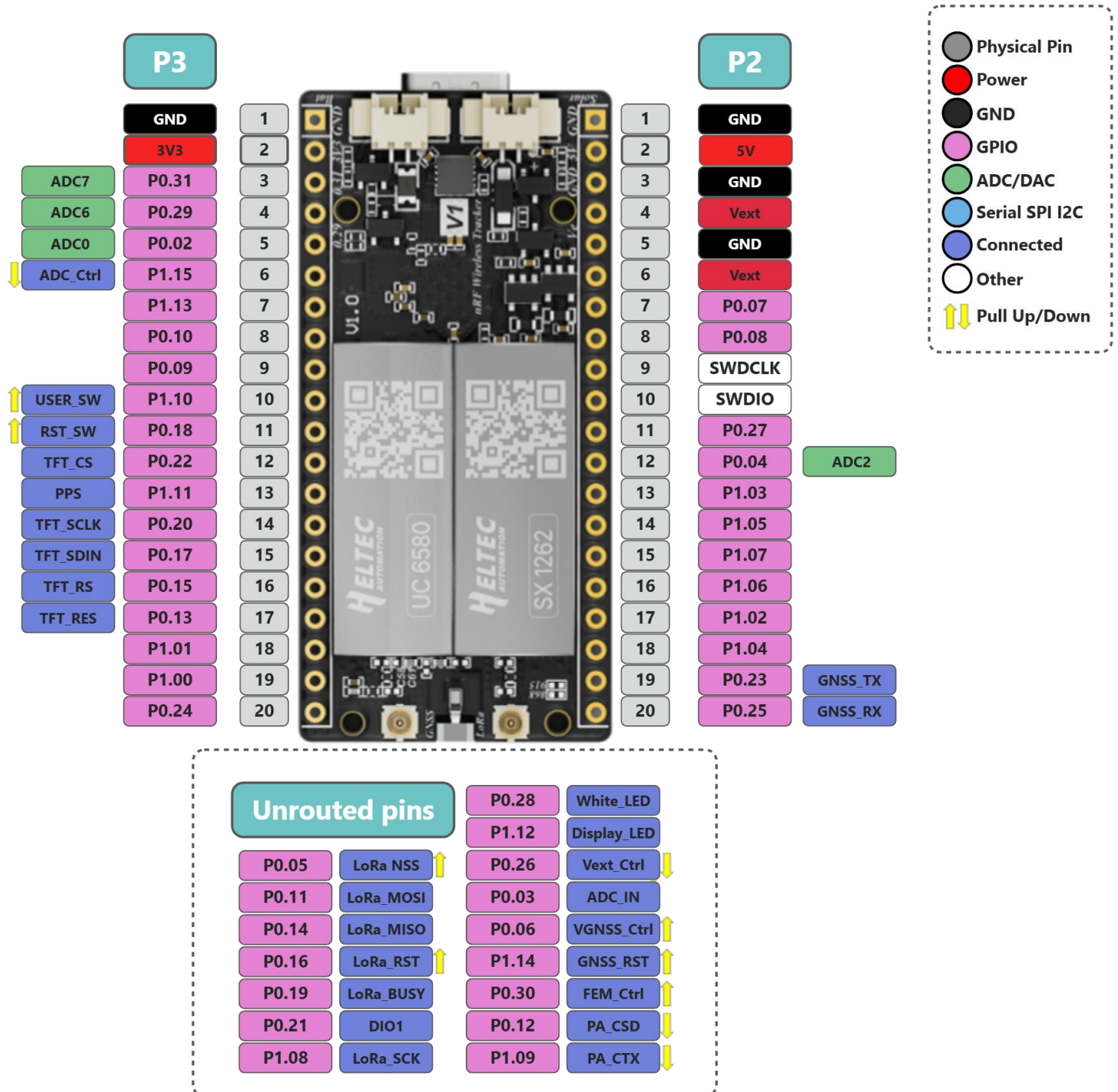

2.1 P2

PHY	Name	Type	Description
1	GND	P	Ground
2	5V	P	5V Power
3	GND	P	Ground
4	Vext	P	3V3 output
5	GND	P	Ground
6	Vext	P	3V3 output
7	P0.07	I/O	GPIO0.07
8	P0.08	I/O	GPIO0.08
9	SWDCLK	I/O	SWD Clock
10	SWDIO	I/O	SWD Data
11	P0.27	I/O	GPIO0.27
12	P0.04	I/O	GPIO0.04, ADC2
13	P1.03	I/O	GPIO1.03
14	P1.05	I/O	GPIO1.05
15	P1.07	I/O	GPIO1.07
16	P1.06	I/O	GPIO1.06
17	P1.02	I/O	GPIO1.02
18	P1.04	I/O	GPIO1.04
19	P0.23	I/O	GPIO0.23, GNSS_TX
20	P0.25	I/O	GPIO0.25, GNSS_RX

2.2 P3

PHY	Name	Type	Description
1	GND	P	Ground
2	VDD	P	VDD_nRF
3	P0.31	I/O	GPIO0.31, ADC7
4	P0.29	I/O	GPIO0.29, ADC6
5	P0.02	I/O	GPIO0.02, ADC0
6	P1.15	I/O	GPIO1.15, ADC_Ctrl (high enable)
7	P1.13	I/O	GPIO1.13
8	P0.10	I/O	GPIO0.10
9	P0.09	I/O	GPIO0.09
10	P1.10	I/O	GPIO1.10, User Button
11	P0.18	I/O	GPIO0.18, Reset
12	P0.22	I/O	GPIO0.22, CS
13	P1.11	I/O	GPIO1.11, PPS
14	P0.20	I/O	GPIO0.20, SCLK
15	P0.17	I/O	GPIO0.17, SDIN
16	P0.15	I/O	GPIO0.15, RS
17	P0.13	I/O	GPIO0.13, RES
18	P1.01	I/O	GPIO1.01
19	P1.00	I/O	GPIO1.00
20	P0.24	I/O	GPIO0.24

2.3 Unrouted pins

Name	Number	Function
P0.26	GPIO0.26	Vext Ctrl (high enable)
P0.03	GPIO0.03	ADC IN
P0.21	GPIO0.21	DIO1
P0.05	GPIO0.05	LoRa NSS
P1.08	GPIO1.08	LoRa_SCK
P0.11	GPIO0.11	LoRa_MOSI
P0.14	GPIO0.14	LoRa_MISO
P0.16	GPIO0.16	LoRa_RST
P0.19	GPIO0.19	LoRa_BUSY
P0.06	GPIO0.06	VGNSS_Ctrl(low enable)
P1.14	GPIO1.14	GNSS_RST
P0.30	GPIO0.30	FEM_Ctrl
P0.12	GPIO0.12	PA_CSD
P0.28	GPIO0.28	White LED
P1.12	GPIO1.12	Display LED
P1.09	GPIO1.09	PA CTX

3 Specifications

3.1 General Specification

Table3.1: General specification

Parameters	Description
MCU	nRF52840
LoRa Chipset	SX1262
GNSS	UC6580
Memory	1M ROM; 256KB SRAM
Bluetooth	Bluetooth 5, Bluetooth mesh, BLE.
Storage temperature	-30~80°C
Operating temperature	-20~70°C
Operating Humidity	90%(No condensing)
Power Supply	3~5.5V (USB), 3~4.2(Battery)
Display	ST7735S, 0.96 Inch, 80(H)RGB x 160(V)
Active Area	10.8 mm(H) × 21.7(V) mm
Hardware Resource	USB 2.0, 2 x LEDs, 2 x Buttons, 4 x SPI, 2 x TWI, 2 x UART, 4 x PWM, QSPI, I2S, PDM, QDEC Etc.
Interface	Type-C USB, 1.25-2P lithium battery connector, 1.25-2P solar panel connector, LoRa ANT (IPEX1.0), GNSS ANT (IPEX1.0), 2 x 13 x 2.54 Header Pins
Dimensions	52*25.4*10.2 mm

3.2 Power Consumption

Table 3.2: Working current

Mode	Condition	Consumption @3.7V_BAT		
		470MHz	868MHz	915MHz
LoRa_TX	10dBm		152mA	152mA
	16dBm		234mA	237mA

	22dBm		407mA	415mA
	29dBm		776mA	765mA
BT	UART	10mA		
	Scan	2.6mA		
Sleep		13uA		
GNSS		40mA		
Charging	Solar	500mA		
	USB-C	500mA		

3.3 Transmit Power

Table3.3: Transmit power

Operating frequency band(MHz)	Maximum power value/[dBm]
863~870	28 ± 1
902~928	28 ± 1

3.4 Operation Frequencies

Table3.4: Operation Frequencies

Region	Frequency (MHz)	Model
IN868	865~867	HT-n5262G-HF
EU868	863~870	HT-n5262G-HF
US915	902~928	HT-n5262G-HF
AU915	915~928	HT-n5262G-HF
KR920	920~923	HT-n5262G-HF
AS923	920~925	HT-n5262G-HF

4 Physical Dimensions

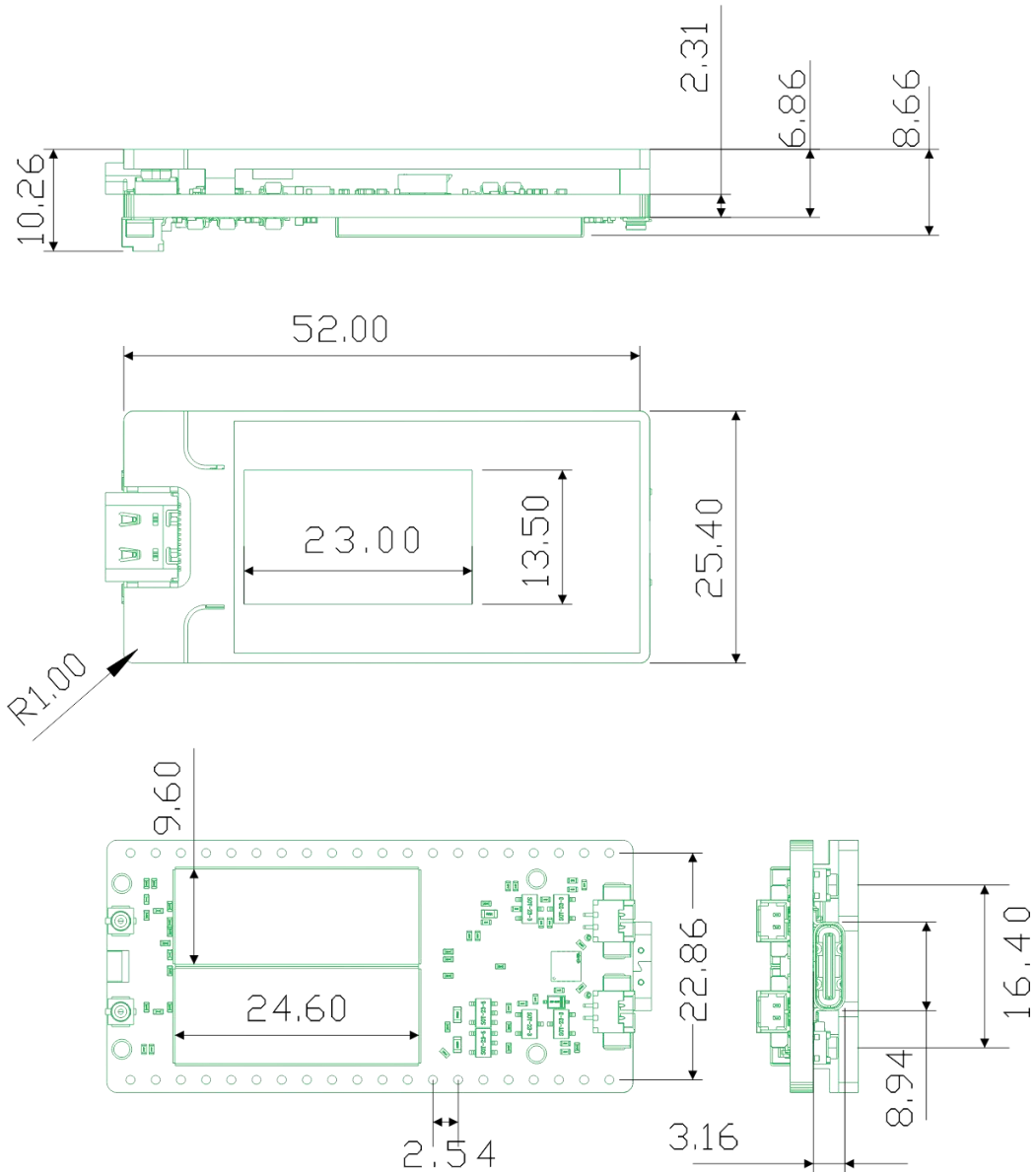

5 Resource

- [Mesh Node T096 Schematic Diagram](#)
- **SDK:** [Heltec nRF52 framework and Lib](#)
- [SnapEmu LoRaWAN IoT Platform](#)
- [Mesh Node T096 Manual Document](#)
- [TFT-LCD Datasheet](#)
- [GNSS Documents](#)

<https://heltec.org>

6 Heltec Contact Information

Heltec Automation Technology Co., Ltd

Chengdu, Sichuan, China

Email: support@heltec.cn

Phone: +86-028-62374838

<https://heltec.org>