

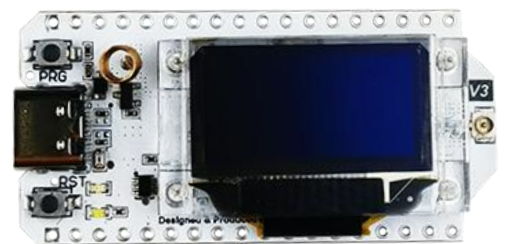

## WiFi LoRa 32 V3.2

### LoRa Node Development Kit





## Document version

Version	Time	Description	Remark
V1.0	2022-08-16	Documents creating	肖鸿
V1.1	2022-09-21	Document structure update	Aaron
V1.2	2024-09-01	V3.1	Richard
V1.3	2024-10-11	V3.2 <sup>1</sup>	Richard

---

1



## Copyright Notice

All contents in the files are protected by copyright law, and all copyrights are reserved by Chengdu Heltec Automation Technology Co., Ltd. (hereinafter referred to as Heltec). Without written permission, all commercial use of the files from Heltec are forbidden, such as copy, distribute, reproduce the files, etc., but non-commercial purpose, downloaded or printed by individual are welcome.

## Disclaimer

Chengdu Heltec Automation Technology Co., Ltd. reserves the right to change, modify or improve the document and product described herein. Its contents are subject to change without notice. These instructions are intended for you use.



# Content

<b>WiFi LoRa 32 V3.2</b> .....	<b>1</b>
<i>Document version</i> .....	2
<i>Copyright Notice</i> .....	3
<i>Disclaimer</i> .....	3
<b>1. Description</b> .....	<b>5</b>
1.1 <i>Overview</i> .....	5
1.2 <i>Product features</i> .....	5
<b>2. Pin Definition</b> .....	<b>7</b>
2.1 <i>Pin assignment</i> .....	7
2.2 <i>Pin description</i> .....	7
<b>3. Specifications</b> .....	<b>10</b>
3.1 <i>General specifications</i> .....	10
3.2 <i>Power supply</i> .....	11
3.3 <i>Power output</i> .....	11
3.4 <i>Power characteristics</i> .....	11
3.5 <i>LoRa RF characteristics</i> .....	12
3.5.1 <i>Transmit power</i> .....	12
3.5.2 <i>Receiving sensitivity</i> .....	12
3.6 <i>Operation Frequencies</i> .....	13
<b>4. Hardware resource</b> .....	<b>错误! 未定义书签。</b>
4.1 <i>Physical dimensions</i> .....	14
<b>5. Resource</b> .....	<b>14</b>
5.1 <i>Relevant Resource</i> .....	14
5.2 <i>Contact Information</i> .....	15



# 1. Description

## 1.1 Overview

[WiFi LoRa 32](#) is a classic IoT dev-board designed & produced by Heltec Automation. It features rich pins and a 0.96-inch OLED display. Since its launch in 2017, it has been loved by developers and makers. Thanks to the three communication methods of Wi-Fi, Bluetooth, and LoRa provided by the esp32 + SX1262, the device has been widely used in the fields of Internet of Things development and long-distance communication.

WiFi LoRa 32 are available in two product variants:

Table 1.1: Product model list

No.	Model	Description
1	LF	470~510MHz working LoRa frequency, used for China mainland (CN470) LPW band.
2	HF	For EU868, IN865, US915, AU915, AS923, KR920 and other LPW networks with operating frequencies between 863~928MHz.

## 1.2 Difference between V3 and V2

	WiFi LoRa 32 (V2)	WiFi LoRa 32 (V3)
MCU	ESP32-D0	ESP32-S3
LoRa Chip	SX1276	SX1262
USB Socket	Micro USB	Type C
Crystal Oscillator	Ordinary crystal oscillator	High precision temperature



		compensated crystal oscillator
<b>Low Power</b>	800uA	<10uA
<b>Other</b>		Better impedance matching of RF circuits.

### 1.3 Product features

- Microprocessor: ESP32-S3FN8 (Xtensa® 32-bit LX7 dual core processor, five stage pipeline rack Structure, main frequency up to 240 MHz).
- SX1262 LoRa node chip.
- Type-C USB interface with a complete voltage regulator, ESD protection, short circuit protection, RF shielding, and other protection measures.
- Onboard SH1.25-2 battery interface, integrated lithium battery management system (charge and discharge management, overcharge protection, battery power detection, USB / battery power automatic switching).
- Integrated WiFi, LoRa, Bluetooth three network connections, onboard Wi-Fi, Bluetooth dedicated 2.4GHz metal spring antenna, reserved IPEX (U.FL) interface for LoRa use.
- Onboard 0.96-inch 128\*64 dot matrix OLED display, which can be used to display debugging information, battery power, and other information.
- Integrated CP2102 USB to serial port chip, convenient for program downloading, debugging information printing.
- Support the [Arduino development environment](#).
- We provide [ESP32 + LoRaWAN](#) protocol Arduino® library, this is a standard

<https://heltec.org>

LoRaWAN protocol that can communicate with any LoRa gateway running the LoRaWAN protocol. In order to make this code running, a unique license is needed. It can be found on [this page](#);

- With good RF circuit design and low-power design.

## 2. Pin Definition

### 2.1 Pin assignment

#### Wi-Fi LoRa 32 Pin Map

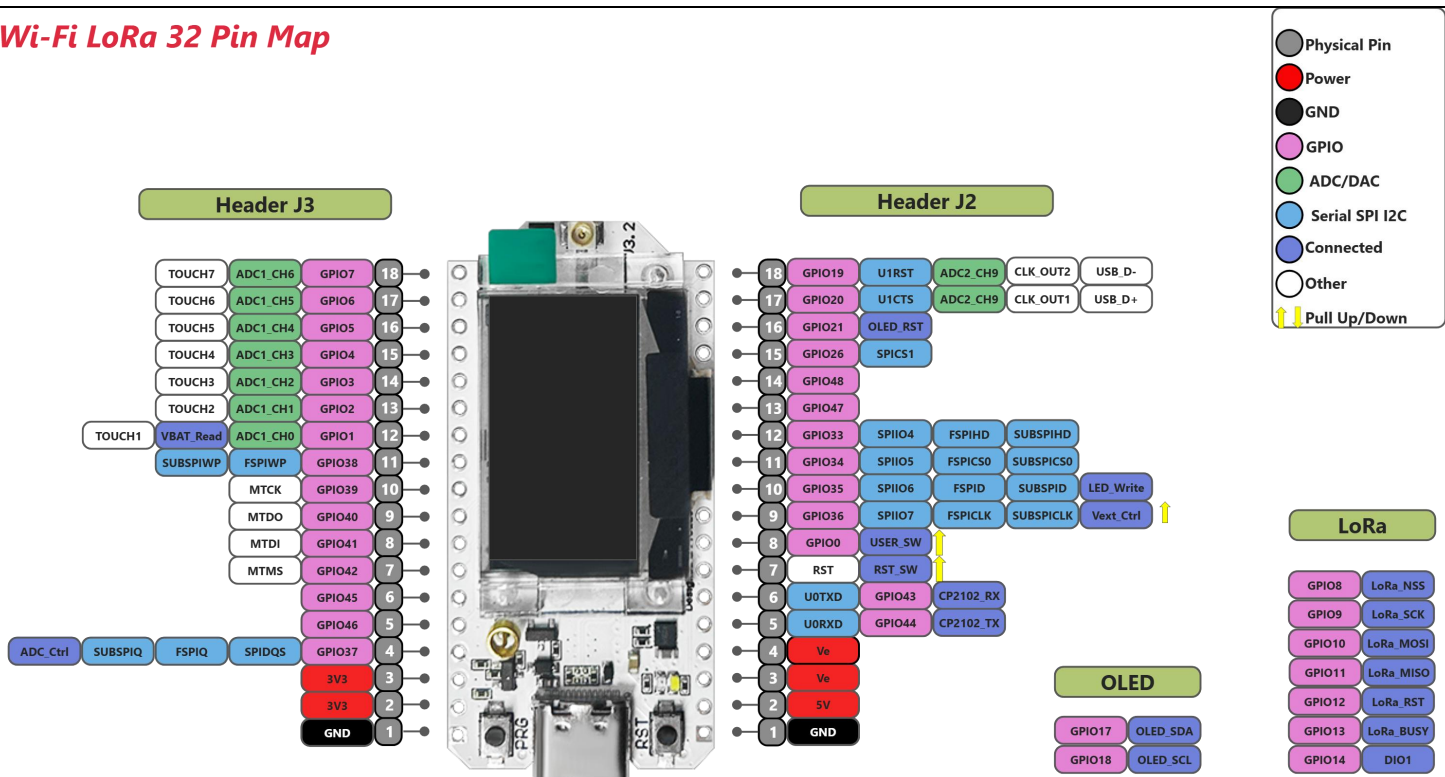

### 2.2 Pin description

- Header J2

<https://heltec.org>



Table 2.2-1: Pin description

No.	Name	Type	Function
1	GND	P	Ground.
2	5V	P	5V Power Supply.
3	Ve	P	Output 3.3V, power supply for external sensor.
4	Ve	P	Output 3.3V, power supply for external sensor.
5	RX	I/O	GPIO44, U0RXD, connected to CP2102 TXD
6	TX	I/O	GPIO43, U0RXD, connected to CP2102 RXD
7	RST	I	CHIP_PU, connected to RST switch
8	0	I/O	GPIO0, connect to PRG switch
9	36	I/O	GPIO36, SPII07, FSPICLK, SUBSPICLK, Vext Ctrl
10	35	I/O	GPIO35, SPII06, FSPID, SUBSPID, LED Write Ctrl
11	34	I/O	GPIO34, SPII05, FSPICS0, SUBSPICS0.
12	33	I/O	GPIO33, SPII04, FSPIHD, SUBSPIHD.
13	47	I/O	GPIO47, SPICLK_P_DIFF, SUBSPICLK_P_DIFF.
14	48	I/O	GPIO48, SPICLK_N_DIFF, SUBSPICLK_N_DIFF.
15	26	I/O	GPIO26, SPICS1.
16	21	I/O	GPIO21, OLED RST
17	20	I/O	GPIO20, U1CTS, ADC2_CH9, CLK_OUT1, USB_D+ <sup>2</sup> .
18	19	I/O	GPIO19, U1RTS, ADC2_CH8, CLK_OUT2, USB_D- <sup>3</sup> .

### Header J3

<sup>2</sup> DP pin connectable to USB socket, solder R29

<sup>3</sup> DN pin connectable to USB socket, solder R3

<https://heltec.org>





Table 2.2-2: Pin description

No.	Name	Type	Function
1	GND	P	Ground.
2	3V3	P	3.3V Power Supply.
3	3V3	P	3.3V Power Supply.
4	37	I/O	GPIO37, SPIDQS, FSPIQ, SUBSPIQ.
5	46	I/O	GPIO46.
6	45	I/O	GPIO45.
7	42	I/O	GPIO42, MTMS.
8	41	I/O	GPIO41, MTDI.
9	40	I/O	GPIO40, MTDO.
10	39	I/O	GPIO39, MTCK.
11	38	I/O	GPIO38, FSPIWP, SUBSPIWP.
12	1	I/O	GPIO1, ADC1_CH0 <sup>4</sup> , TOUCH1, Read VBAT Voltage
13	2	I/O	GPIO2, ADC1_CH1, TOUCH2.
14	3	I/O	GPIO3, ADC1_CH2, TOUCH3.
15	4	I/O	GPIO4, ADC1_CH3, TOUCH4.
16	5	I/O	GPIO5, ADC1_CH4, TOUCH5.
17	6	I/O	GPIO6, ADC1_CH5, TOUCH6.
18	7	I/O	GPIO7, ADC1_CH6, TOUCH7.

<sup>4</sup> ADC1\_CH0 is used to read the lithium battery voltage, the voltage of the lithium battery is:

$$VBAT = 100 / (100+390) * VADC\_IN1$$

<https://heltec.org>



## 3. Specifications

### 3.1 General specifications

Table 3.1: General specifications

Parameters	Description
<b>Master Chip</b>	ESP32-S3FN8 (Xtensa®32-bit lx7 dual core processor)
<b>LoRa Chipset</b>	SX1262
<b>USB to Serial Chip</b>	CP2102
<b>Frequency</b>	470~510 MHz, 863~928 MHz
<b>Max. TX Power</b>	21 ± 1 dBm
<b>Max. Receiving sensitivity</b>	-137 dBm
<b>Wi-Fi</b>	802.11 b/g/n, up to 150Mbps
<b>Bluetooth</b>	Bluetooth LE: Bluetooth 5, Bluetooth mesh
<b>Hardware Resource</b>	7*ADC1 + 2*ADC2; 7*Touch; 3*UART; 2*I2C; 2*SPI; etc.
<b>Memory</b>	384KB ROM; 512KB SRAM; 16KB RTC SRAM; 8MB SiP Flash
<b>Interface</b>	Type-C USB; 2*1.25 lithium battery interface; LoRa ANT(IPEX1.0); 2*18*2.54 Header Pin
<b>Battery</b>	3.7V lithium battery power supply and charging
<b>Operating temperature</b>	-20 ~ 70 °C
<b>Dimensions</b>	50.2 * 25.5* 10.2 mm



### 3.2 Power supply

Except when USB or 5V Pin is connected separately, lithium battery can be connected to charge it. In other cases, only a single power supply can be connected.

Table 3.2: Power supply

Power supply mode	Minimum	Typical	Maximum	Company
Type-C USB( $\geq 500\text{mA}$ )	4.7	5	6	V
Lithium battery( $\geq 250\text{mA}$ )	3.3	3.7	4.2	V
5V pin( $\geq 500\text{mA}$ )	4.7	5	6	V
3V3 pin( $\geq 150\text{mA}$ )	2.7	3.3	3.5	V

### 3.3 Power output

Table 3.3: Power output

Output Pin	Minimum	Typical	Maximum	Company
3.3V Pin			500	mA
5V Pin (USB Powered only)			500	mA
Vext Pin			350	mA

### 3.4 Power characteristics

Table 3.4: Power characteristics

Mode	Condition	Min.	Typical	Max.	Company
WiFi Scan	USB powered		115		mA
WiFi AP	USB powered		150		mA
BT	USB powered		115		mA



TX	14dBm, USB powered, 868		200	mA
	17dBm, USB powered, 868		210	mA
	22dBm, USB powered, 868		230	mA
RX	TX disabled; RX enabled		90	mA
sleep	USB powered		2	mA
	VBAT/battery powered		15	uA
	3.3V header powered		10	uA

### 3.5 LoRa RF characteristics

#### 3.5.1 Transmit power

Table3.5.1: Transmit power

Operating frequency band	Maximum power value/[dBm]
470~510	21 ± 1
867~870	21 ± 1
902~928	21 ± 1

#### 3.5.2 Receiving sensitivity

The following table gives typically sensitivity level of the HTIT-WB32LA.

Table3.5.2: Receiving sensitivity

Signal Bandwidth/[KHz]	Spreading Factor	Sensitivity/[dBm]
------------------------	------------------	-------------------

<https://heltec.org>



125	SF12	-137
125	SF10	-130
125	SF7	-124

### 3.6 Operation Frequencies

HTIT-WB32LA supports LoRaWAN frequency channels and models corresponding table.

Table3.6: Operation Frequencies

Region	Frequency (MHz)	Model
EU433	433.175~434.665	LF
CN470	470~510	LF
IN868	865~867	HF
EU868	863~870	HF
US915	902~928	HF
AU915	915~928	HF
KR920	920~923	HF
AS923	920~925	HF



## 4. Physical dimensions

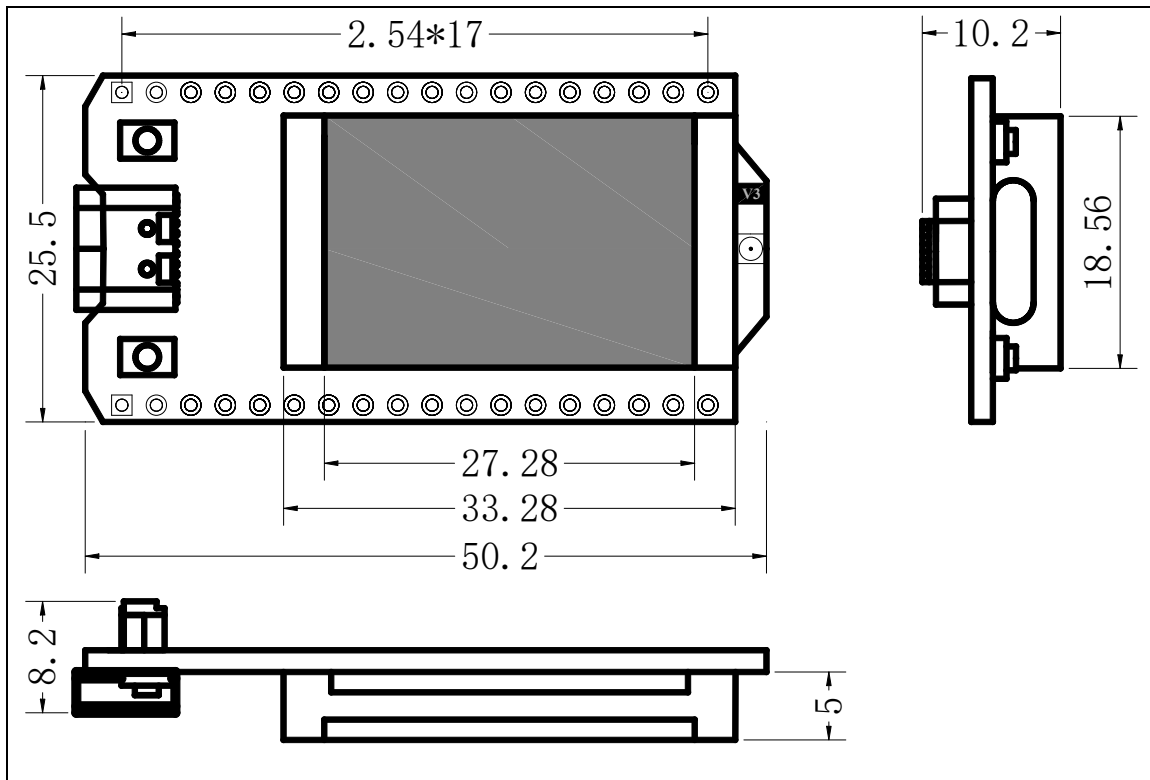

## 5. Resource

### 5.1 Relevant Resource

- Source Code
  - [Heltec ESP \(ESP32 & ESP8266\) framework](#)
  - [Heltec ESP32 library](#)
- [Schematic diagram](#)
  - [V3](#)
  - [V3.2](#)
- [Pin map](#)
- [Downloadable resource](#)

<https://heltec.org>



## 5.2 Contact Information

Heltec Automation Technology Co., Ltd

Chengdu, Sichuan, China

Email: [support@heltec.cn](mailto:support@heltec.cn)

Phone: +86-028-62374838

<https://heltec.org>