



[Wireless Tracker V1.1](#)

Wi-Fi/LoRa/BLE/GNSS(L5)

Development Kit



<https://heltec.org>



Document version

Version	Time	Description	Remark
V1.0	2023-05-16	Documents creating	Richard
V1.1	2023-05-21	Document structure update	Richard
V1.1.1	2024-10-10	Update the GNSS module parameter description	Richard

Copyright Notice

All contents in the files are protected by copyright law, and all copyrights are reserved by Chengdu Heltec Automation Technology Co., Ltd. (hereinafter referred to as Heltec). Without written permission, all commercial use of the files from Heltec are forbidden, such as copy, distribute, reproduce the files, etc., but non-commercial purpose, downloaded or printed by individual are welcome.

Disclaimer

Chengdu Heltec Automation Technology Co., Ltd. reserves the right to change, modify or improve the document and product described herein. Its contents are subject to change without notice. These instructions are intended for you use.



Content

Wireless Tracker	1
<i>Document version</i>	2
<i>Copyright Notice</i>	2
<i>Disclaimer</i>	2
<i>Content</i>	3
1. <i>Description</i>	4
1.1 <i>Overview</i>	4
1.2 <i>Product features</i>	5
2. <i>Pin Definition</i>	6
2.1 <i>Pin assignment</i>	6
2.2 <i>Pin description</i>	7
3. <i>Specifications</i>	10
3.1 <i>General specifications</i>	10
3.2 <i>Power supply</i>	11
3.3 <i>Power output</i>	11
3.4 <i>Power characteristics</i>	12
3.5 <i>LoRa RF characteristics</i>	12
3.6 <i>GNSS Characteristics</i>	14
4. <i>Typical hardware connections</i>	错误! 未定义书签。
4.1 <i>Physical dimensions</i>	16
5. <i>Resource</i>	16
5.1 <i>Relevant Resource</i>	16
5.2 <i>Contact Information</i>	16



1. Description

1.1 Overview

Wireless Tracker is a development kit based on ESP32-S3FN8. It integrates both SX1262 and UC6580 to provide fast GNSS solution for IoT. Collaborate with the sample programs and development tools we provide, you can track any object and then upload that data wirelessly by Wi-Fi, Bluetooth, LoRa.

Wireless Tracker supports L1 + L5 and supports GPS, GLONASS, BDS, Galileo, NAVIC, QZSS multi-system joint positioning. It is perfectly compatible with Arduino, can be widely used in development such as bicycle sharing services, tracking pets or livestock, locating vehicles, tracking children, etc.

Wireless Tracker are available in two product variants:

Table 1.1: Product model list

No.	Model	Description
1	Wireless Tracker-LF	470~510MHz working LoRa frequency, used for China mainland (CN470) LPW band.
2	Wireless Tracker-HF	For EU868, IN865, US915, AU915, AS923, KR920 and other LPW networks with operating frequencies between 863~928MHz.



1.2 Product features

- ESP32-S3FN8+SX1262+UC6580 Chipset, supports Wi-Fi, LoRa, Bluetooth, GNSS.
- Low power design of dual-frequency multi-system based on 22nm technology.
- Supports L1 + L5, supports GPS, GLONASS, BDS, Galileo, NAVIC, QZSS multi-system joint positioning.¹
- Type-C USB interface with a complete voltage regulator, ESD protection, short circuit protection, RF shielding, and other protection measures.
- Onboard SH1.25-2 battery interface, integrated lithium battery management system (charge and discharge management, overcharge protection, battery power detection, USB / battery power automatic switching).
- Onboard Wi-Fi, Bluetooth dedicated 2.4GHz metal spring antenna, reserved IPEX (U.FL) interface for LoRa and GNSS use.
- Onboard 0.96-inch 80(H) x 160(V) RGB TFT-LCD display, which can be used to display debugging information, battery power, and other information.
- Support the [Arduino development environment](#).

¹ See the GNSS module manual for details on supported projects: [UFirebird_Standard Positioning Products Protocol Specification](#)

2. Pin Definition

2.1 Pin assignment

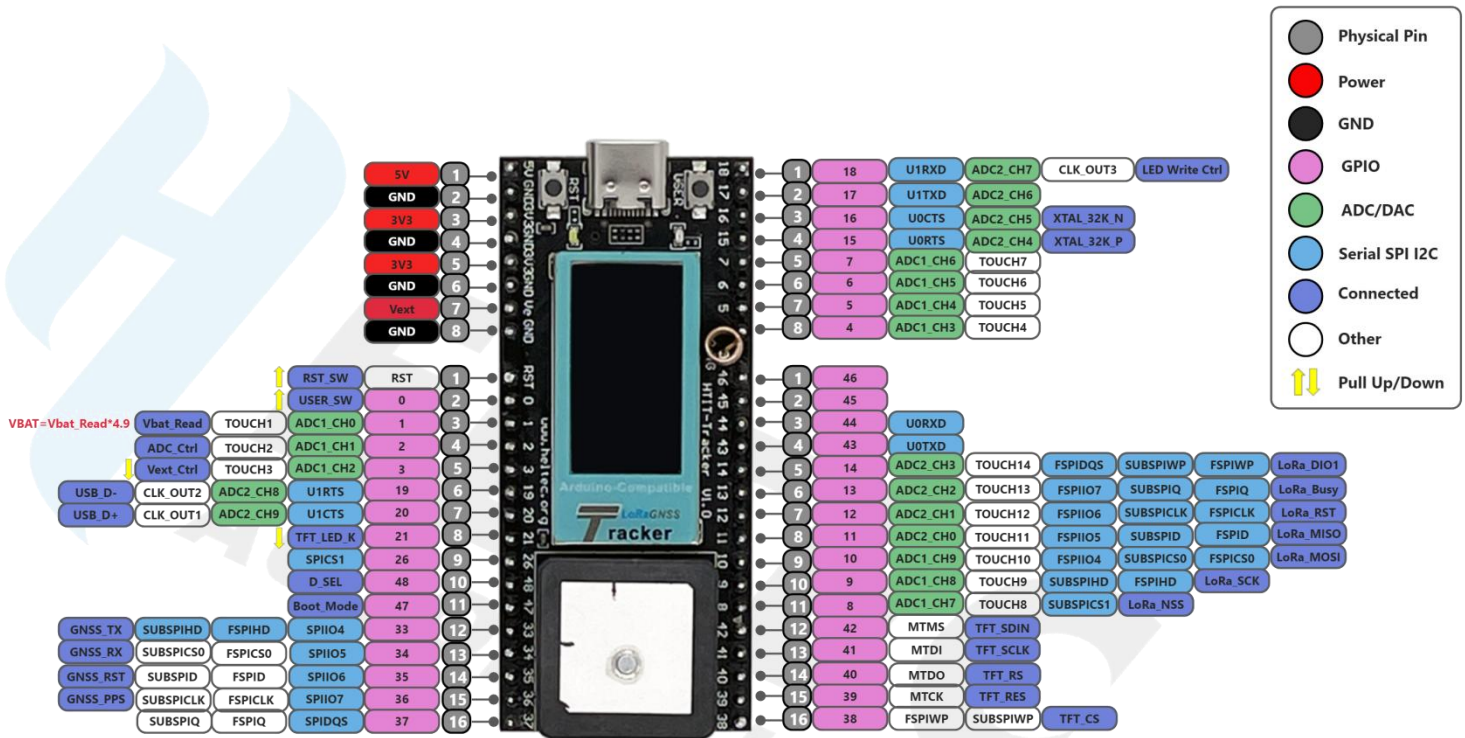



2.2 Pin description

Header J2

Table 2-2-1: Pin description

No.	Name	Type	Function
1	5V	P	5V Power Supply
2	GND	P	Ground
3	3V3	P	Output 3.3V
4	GND	P	Ground
5	3V3	P	Output 3.3V
6	GND	P	Ground
7	Vext	P	Output 3.3V, power supply for built-in TFT and GNSS
8	GND	P	Ground
1	RST	P	RST_SW
2	0	I/O	GPIO0, USER_SW
3	1	I/O	GPIO1, Vbat_Read ² , Touch1, ADC1_CH0
4	2	I/O	GPIO2, ADC Ctrl, Touch1, ADC1_CH0
5	3	I/O	GPIO3, Vext Ctrl , Touch1, ADC1_CH0
6	19	I/O	GPIO19, USB_D-, CLK_OUT2, ADC2_CH8, U1RTS
7	20	I	GPIO20, USB_D+, CLK_OUT1, ADC2_CH9, U1CTS
8	21	I/O	GPIO21, TFT_LED_K
9	26	I/O	GPIO26, SPICS1
10	48	I/O	GPIO48, D_SEL

² VBAT=Vbat_Read*4.9



11	47	I/O	GPIO47, Boot_Mode
12	33	I/O	GPIO33, SPIO4, FSPIHD, SUBSPIHD, GNSS_TX
13	34	I/O	GPIO34, SPIO5, FSPIC0, SUBSPIC0, GNSS_RX
14	35	I/O	GPIO35, SPIO6, FSPID, SUBSPID, GNSS_RST
15	36	I/O	GPIO36, SPIO7, FSPICLK, SUBSPICLK, GNSS_PPS
16	37	I/O	GPIO37, SPIDQS, FSPIQ, SUBSPIQ

Header J3

Table 2-2-2: Pin description

No.	Name	Type	Function
1	18	I/O	GPIO18, U1RXD, ADC2_CH7, CLK_OUT3, LED Write Ctrl
2	17	I/O	GPIO17, U1TXD, ADC2_CH6
3	16	I/O	GPIO16, U0CTS, ADC2_CH5, XTAL_32K_N
4	15	I/O	GPIO15, U0RTS, ADC2_CH4, XTAL_32K_P
5	7	I/O	GPIO7, ADC1_CH6, TOUCH7
6	6	I/O	GPIO6, ADC1_CH5, TOUCH6
7	5	I/O	GPIO5, ADC1_CH4, TOUCH5
8	4	I/O	GPIO4, ADC1_CH3, TOUCH4
1	46	I/O	GPIO46
2	45	I/O	GPIO45
4	44	I/O	GPIO44, U0RXD
5	43	I/O	GPIO43, U0TXD
6	14	I/O	GPIO14, ADC2_CH3, TOUCH14, FSPIDQS, SUBSPIWP, FSPIWP, LoRa_DIO1

<https://heltec.org>



7	13	I/O	GPIO13, ADC2_CH2, TOUCH13, FSPIIO7, SUBSPIQ, FSPIQ, LoRa_Busy
8	12	I/O	GPIO12, ADC2_CH1, TOUCH12, FSPIIO6, SUBSPICLK, FSPICLK, LoRa_RST
9	11	I/O	GPIO11, ADC2_CH0, TOUCH11, FSPIIO5, SUBSPID, FSPID, LoRa_MISO
10	10	I/O	GPIO10, ADC1_CH9, TOUCH10, FSPIIO4, SUBSPICS0, FSPICS0, LoRa_MOSI
11	9	I/O	GPIO9, ADC1_CH8, TOUCH9, SUBSPIHD, FSPIHD, LoRa_SCK
12	8	I/O	GPIO8, ADC1_CH7, TOUCH8, SUBSPICS1, LoRa_NSS
13	42	I/O	GPIO42, MTMS, TFT_SDIN
14	41	I/O	GPIO41, MTDI, TFT_SCLK
15	40	I/O	GPIO40, MTMS, TFT_RS
16	39	I/O	GPIO39, MTMS, TFT_RES
18	38	I/O	GPIO38, FSPIWP, SUBSPIWP, TFT_CS



3. Specifications

3.1 General specifications

Table 3-1: General specifications

Parameters	Description
Master Chip	ESP32-S3FN8 (Xtensa®32-bit lx7 dual core processor)
LoRa Chipset	SX1262
GNSS Chipset	UC6580
Frequency	470~510MHz, 863~928MHz
Max TX Power	21 ± 1dBm
Receiving sensitivity	-135dBm
Wi-Fi	802.11 b/g/n
Bluetooth	Bluetooth LE: Bluetooth 5, Bluetooth mesh
Interface	Type-C USB; 2*1.25 lithium battery interface; LoRa ANT(IPEX); GNSS ANT(IPEX)
Battery	3.7V lithium battery power supply and charging
Operating temperature	-20 ~ 70°C
Dimensions	65.48mm* 28.06mm* 13.52mm



3.2 Power supply

Except when USB or 5V Pin is connected separately, lithium battery can be connected to charge it.

In other cases, only a single power supply can be connected.

Table 3-2: Power supply

Power supply mode	Minimum	Typical	Maximum	Company
Type-C USB($\geq 500\text{mA}$)	4.7	5	6	V
Lithium battery($\geq 250\text{mA}$)	3.3	3.7	4.2	V
5V pin($\geq 500\text{mA}$)	4.7	5	6	V
3V3 pin($\geq 150\text{mA}$)	2.7	3.3	3.5	V

3.3 Power output

Table 3-3: Power output

Output Pin	electric current	Company
3.3V Pin	500	mA
5V Pin (USB Powered only)	500	mA
Vext Pin	350	mA



3.4 Power characteristics

Table 3-4: Power characteristics

Mode	USB power	VBAT/battery powered		Unit
Wi-Fi Scan	100	74		mA
Wi-Fi AP	150	111		mA
BT	102	75		mA
GNSS	120	89		mA
TX	14dbm	200	148	mA
	17dbm	220	163	mA
	22dbm	240	178	mA
RX	TX disabled; RX enabled	80	59	mA
sleep	2mA		15µA	

3.5 LoRa RF characteristics

3.5.1 Transmit power

Table3-5-1: Transmit power

Operating frequency band	Maximum power value/[dBm]
470~510	21 ± 1
867~870	21 ± 1
902~928	21 ± 1



3.5.2 Receiving sensitivity

The following table gives typically sensitivity level of the Wireless Trackerr-(L/H).

Table3-5-2: Receiving sensitivity

Signal Bandwidth/[KHz]	Spreading Factor	Sensitivity/[dBm]
125	SF12	-135
125	SF10	-130
125	SF7	-124

3.5.3 Operation Frequencies

Wireless Tracker supports LoRaWAN frequency channels and models corresponding table.

Table3-5-3: Operation Frequencies

Region	Frequency (MHz)	Model
EU433	433.175~434.665	Wireless Tracker-LF
CN470	470~510	Wireless Tracker-LF
IN868	865~867	Wireless Tracker-HF
EU868	863~870	Wireless Tracker-HF
US915	902~928	Wireless Tracker-HF
AU915	915~928	Wireless Tracker-HF
KR920	920~923	Wireless Tracker-HF
AS923	920~925	Wireless Tracker-HF



3.6 GNSS Characteristics

3.6.1 Basic information

Table3-6-1: Basic information

Channel	96
Update frequency	Max 10 Hz
Data format	NMEA-0183, Unicore, RTCM 3.x
Frequency point	BDS: B2a
	GPS: L1+L5
	GLONASS: G1
	Galileo: E1+E5a
	QZSS: L1+L5
	SBAS: L1
	NAVIC: L5*(Specific firmware)

3.6.2 Accuracy and TTFF²

Table3-6-2: Accuracy and TTFF²

Horizontal position accuracy(RMS)	1.5m
Vertical position accuracy(RMS)	2.5m
Time accuracy(RMS)	5ns
Speed accuracy	0.02m/s ³
Cold boot	< 26s

³ -33 mps linear uniform motion scene under the simulator



Warm boot	< 2s
Recapture	1s

3.6.3 Sensitivity (Unit: dBm)

Talbe3-6-2: Sensitivity

Sensitivity	GNSS	BDS	GPS	GAL	GLONASS
Cold boot	-148	-146	-148	-144	-144
Warm boot	-156	-155	-155	-154	-148
Trace	-165	-163	-165	-163	-158
Recapture	-156	-154	-156	-154	-152

4. Physical dimensions

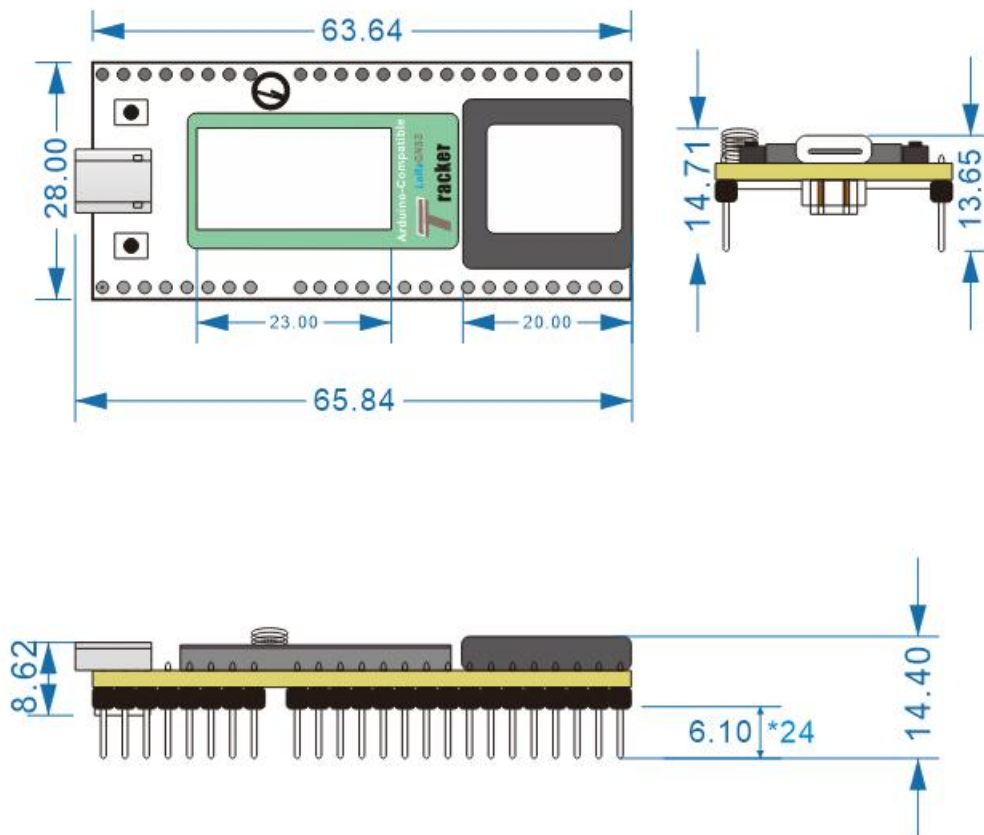

5. Resource

5.1 Relevant Resource

- [Heltec ESP \(ESP32 & ESP8266\) framework](#) (Already included Heltec ESP32 LoRaWAN library)
- [Heltec LoRaWAN test server based on TTS V3](#)
- [User Manual Document](#)

5.2 Contact Information

Heltec Automation Technology Co., Ltd

<https://heltec.org>



Chengdu, Sichuan, China

Email: support@heltec.cn

Phone: +86-028-62374838

<https://heltec.org>

<https://heltec.org>

Documents

Rev 1.1

P 17/17

May 2023

Heltec Automation © Limited standard files